

## INSTALLER:

Leave this manual with the appliance.

## CONSUMER:

Retain this manual for future reference.

### ⚠ WARNING

If the information in this manual is not followed exactly, a fire or explosion may result causing property damage, personal injury or loss of life.

- Do not store or use gasoline or other flammable vapors and liquids in the vicinity of this or any other appliance.
- **WHAT TO DO IF YOU SMELL GAS**
  - Do not try to light any appliance.
  - Do not touch any electrical switch; do not use any phone in your building.
  - Immediately call your gas supplier from a neighbor's phone. Follow the gas supplier's instructions.
  - If you cannot reach your gas supplier, call the fire department.
- Installation and service must be performed by a qualified installer, service agency or the gas supplier.

### ⚠ WARNING

**"FIRE, EXPLOSION, AND ASPHYXIATION HAZARD** Improper adjustment, alteration, service, maintenance or installation of this heater or its controls can cause death or serious injury. Read and follow instructions and precautions in User's Information Manual provided with this heater."

**This is an unvented gas-fired heater. It uses air (oxygen) from the room in which it is installed. Provisions for adequate combustion and ventilation air must be provided. Refer to pages 15.**

## CONTEMPORARY LINEAR VENT-FREE GAS FIREPLACE MODEL:

VFLB(36,48)FP30(N,P)-3

VFLB(36,48,60,72)FP90(N,P)-4



This appliance may be installed in an aftermarket, permanently located, manufactured (mobile) home, where not prohibited by local codes. This appliance is only for use with the type of gas indicated on the rating plate. This appliance is not convertible for use with other gases.

NATIONAL  
FIREPLACE  
INSTITUTE



**CERTIFIED**

[www.nficertified.org](http://www.nficertified.org)  
Our gas hearth products must be installed and serviced by professionals who are certified in the U.S. by the National Fireplace Institute® (NFI) as NFI Gas Specialists.

**GAS-FIRED**



**LISTED**

**UL FILE NO. MH46389**  
This series is design certified in accordance with American National Standard Institute (ANSI) Z21.11.2 by the Canadian Standards Association Laboratories (CSA) as an Unvented Room Fireplace and should be installed according to these instructions.

### NOTICE: Contact your dealer for installation, service, repair, or warranty claim

Empire Comfort Systems does not sell, service, or provide warranty directly to consumers. The consumer must contact the dealer where the product was purchased for a warranty claim. If a non-qualified installer or consumer installs or services this product, the product warranty is voided. Most dealers will only service products they sold so it is important for the consumer to choose a qualified dealer for installation and warranty service. In order to maintain the warranty, service must be performed annually and documentation reviewed during the warranty request.

# TABLE OF CONTENTS

SECTION	PAGE
Important Soot Prevention Steps .....	3
Before You Start .....	4
Carton Contents .....	5
Hardware Pack .....	6
Product Specifications .....	7
Homeowner Reference Information .....	8
Accessories .....	9 - 10
Introduction .....	11
Important Information .....	12
Important Safety Information .....	13
Safety Information for Users of Propane Gas .....	14
Important Installation Guidelines .....	15
Water Vapor: A By-Product of Unvented Room Heaters .....	15
Provisions for Adequate Combustion And Ventilation Air .....	16 - 17
Fireplace Dimensions .....	18
Clearances .....	19
Adding Nailing Flanges And Standoff Brackets .....	20 - 21
Utility Installation .....	22 - 27
Installation OPTION 1 - Clean Face .....	28
OPTION 1 - Clean Face (Non - Combustible Board Installation) .....	29 - 31
Installation OPTION 2 - Flush Mount .....	32
OPTION 2 - Flush Face (Non - Combustible Board Installation) .....	33 - 35
Completing Installation .....	36 - 37
Intermittent Pilot Valve Lighting Instructions .....	38
Millivolt Control Valve Lighting Instructions .....	39
Pilot Flame Characteristics .....	40
Proflame - IP Control System .....	41 - 45
Wiring Diagram - Millivolt Control System .....	46
FRBC - Millivolt Control System .....	47 - 49
Cleaning And Servicing .....	50
Troubleshooting - Intermittent Pilot Control System .....	51 - 53
Troubleshooting - Millivolt Control System .....	54 - 55
VFLB(36,48)FP90 - Exploded View .....	56
VFLB(36,48)FP90 - Parts List .....	57
VFLB(36,48)FP30 - Exploded View .....	58
VFLB(36,48)FP30 - Parts List .....	59
VFLB(60,72)FP90 - Exploded View .....	60
VFLB(60,72)FP90 - Parts List .....	61
Master Parts Distributor List .....	62
How To Order Repair Parts .....	62
Warranty .....	63

# IMPORTANT SOOT PREVENTION STEPS

## IMPORTANT NOTICE

INSTALLER - SERVICE PERSON - HOMEOWNER

SOOT MAY BE CREATED IF THE FOLLOWING DIRECTIONS ARE NOT FOLLOWED

### WARNING

**Failure to keep the primary air openings of the burner clean may result in sooting and property damage.**

### WARNING

**Before installing in a solid-fuel burning fireplace, the chimney flue and firebox must be cleaned of soot, creosote, ashes and loose paint by a qualified chimney cleaner.**

A vent-free fireplace or burner draws room air to support combustion. Lightweight particles suspended in the air – including dust, carpet fibers, candle or tobacco smoke, and pet hair – will be drawn toward the fireplace. These can lead to soot build-up on logs, fireplace walls, and even walls of the room. To prevent malfunctions and sooting, have your dealer inspect and clean each year – before the heating season. If you have pets or excessive dust, more frequent cleaning may be necessary. See cleaning and service section in this manual.

### WARNING

**Do not allow fans to blow directly into or at the fireplace. Avoid any drafts that alter burner flame patterns. Avoid any drafts that alter burner flame patterns. Pay particular attention to ceiling fans and exhaust fans.**

1. Ensure the air shutter is set to the specification. **See Figure 1** and bottom **Table on page 7**.
2. Ensure burner, venturi, and air shutter are free of dirt, lint, animal hair (i.e. cat and dog) or anything that may block the needed air flow. See cleaning and service in homeowner manual.
3. Do not place debris, additional logs or other articles on the burner during operation.
4. Do not use scented air fresheners or candles while the fireplace is in operation. They produce residue which may cause soot.
6. Do not place glass media on burner or burner ports. They should only be placed as shown in **Figure 56**.
7. Do not use rock wool (embers) or lava rock.
8. Avoid the use of decorative or scented candles while the fireplace is in operation. Soot may be produced from the by-products of a burning candle. Some candles also produce soot.
9. Annual inspection and cleaning by your dealer or a qualified service technician is recommended to prevent malfunction and/or sooting.
10. Install optional decorative glass accessory according to the instructions on pages 36 and 37.
11. Install optional logs according to the installation instructions. Only use Empire Logs made for this fireplace.
12. Verify the venturi tube is not bent or distorted. The main burner orifice must be centered in the venturi tube to ensure proper combustion and to prevent sooting.

# BEFORE YOU START

## SAMPLE WARNINGS AND DEFINITIONS:

### DANGER

Indicates a hazardous situation which, if not avoided, will result in death or serious injury.

### WARNING

Indicates a hazardous situation which, if not avoided, could result in death or serious injury.

### CAUTION

Indicates a hazardous situation which, if not avoided, could result in minor or moderate injury.

**NOTICE:** Addresses practices not related to personal injury.

## INSTALLATION INFORMATION

1. Read the soot prevention information on page 6.
2. Read the safety information on pages 13 and 14.
3. Frame the opening. See pages 29 - 31 for Clean Face Installation, or 32 - 35 for Flush Mount Installation.
4. Install the gas lines. See pages 22 - 24.
5. Install the wiring. See pages 25 - 27 for IP Control Systems and pages 46 - 48 for Millivolt Control Systems.
6. Install the remote system. See pages 41 - 45 for IP Control Systems and pages 46 - 49 for Millivolt Control Systems.
7. Light the fireplace. See page 38 for IP Control Systems and page 39 for Millivolt Control Systems.
8. For detailed instructions on operating the Proflame - IP Control System, see pages 41 - 45.
9. For detailed instructions on operating the Millivolt Control System, see pages 46 - 49.
10. Show the homeowner how to operate the fireplace. See pages 41 - 45 for IP Control System and pages 46 - 49 for Millivolt Control Systems.
11. Show the homeowner how to do the basic maintenance. See page 50.

## FIREPLACE INSTALLATION GUIDELINES

Determine where to install the fireplace. The fireplace can be mounted on any of these surfaces:

1. A flat hard combustible or non-combustible surface.
2. A raised platform of combustible or non-combustible material.

If the fireplace is installed directly on carpeting, tile or other combustible material other than wood flooring, it must be installed on a metal or wood panel extending the full width and depth of the fireplace.

This fireplace is designed to be installed in a zero-clearance enclosure. This means combustible material such as framing lumber can come in contact with the top and side standoff spacers, and secured to combustible framing using the framing brackets provided.

This fireplace requires an easily accessible gas shut-off valve be installed in the gas supply line prior to its entry to the fireplace.

Determine the following before installation:

- Any desired accessories
- Gas supply piping (left side entrance).
- Electrical connections
- Electrical supply requirements for lights. (120V, 60Hz, 1 Amp) (left side entrance)

A shut-off valve containing a flange and key is recommended.

## UNPACKING THE FIREPLACE

1. Cut binding straps.
2. Remove top of carton.
3. Remove non-combustible board and set aside.
4. Remove remaining carton.
5. Verify that the fireplace and components have not been damaged during shipping.
6. Set fireplace in a location near its final installation location.

## FINISHING OPTIONS

Choose from two finishing options.

**Option 1 - Clean Face:** This type of installation starting on (pages 28, 29, 30 and 31) will allow for finishing around the fireplace opening with high temperature paint.

**Option 2 - Flush Mount:** This type of installation starting on (pages 32, 33, 34 and 35) will allow you to apply tile, marble, stone or other non-combustible material over the face of the fireplace cabinet, up to the fireplace opening flange.

### CAUTION

**PARTS MAY HAVE SHARP EDGES.**

**Wear leather gloves and handle parts carefully to protect hands during unpacking, assembly, and installation.**

# CARTON CONTENTS

Items not shown to scale.

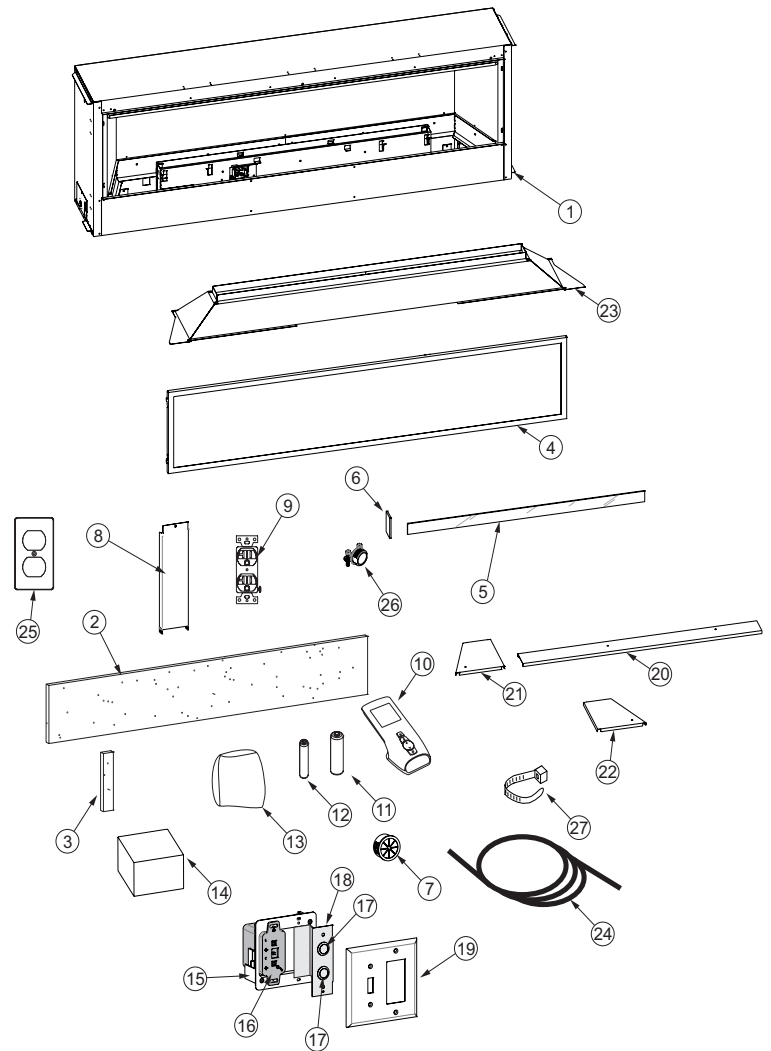
VFLB(36,48,60,72)FP90 SERIES		
Index Number	Description	Quantity Supplied
1	Fireplace	1
2	Non-combustible Board - Top	1
3	Non-combustible Board - Side*	2
4	Barrier Screen Assembly	1
5	Burner Glass	1
6	Side Burner Glass*	2
7	Bushing*	2
8	Standoff Bracket*	3
9	Receptacle*	1
10	Remote*	1
11	AA Battery*	4
12	AAA Battery*	3
13	Hardware Pack*	1
14	AC Adaptor*	1
15	Wall mounted Control Box*	1
16	Remote Receiver*	1
17	Button Switch*	2
18	Mounting Bracket*	1
19	Wall Plate*	1
20	Glass Support Center	2
21	Glass Support Side Left*	1
22	Glass Support Side Right*	1
23	Center Reflector Assembly	1
24	Extension Receiver Harness	1
25	Junction Box Cover*	1
26	Romex Connector*	1
27	Zip Tie*	1

\*Items packaged inside hardware box.

For hardware pack contents, see page 5.

See Parts Lists on pages 57, 59 and 61 for ordering replacement parts. Do not order batteries, bolts, screws, washers or nuts. They are standard hardware items and can be purchased at any local hardware store.

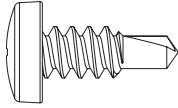
## CARTON CONTENTS



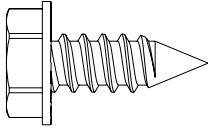
VFLB(60,72)FP9 carton contents shown above.

# HARDWARE PACK

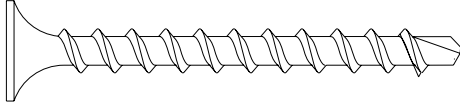
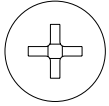
## HARDWARE PACK CONTENTS



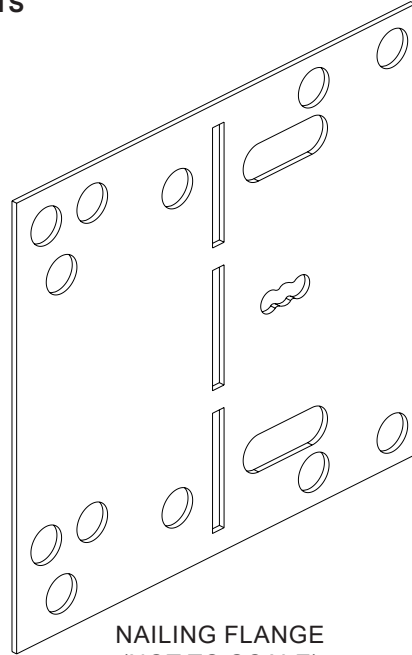
#10-16 X 1/2" STAINLESS PHILLIPS HEAD SCREW



#10 X 1/2" HEX HEAD SCREW



#8 X 1" PHILLIPS SELF-DRILLING DRYWALL SCREW



NAILING FLANGE  
(NOT TO SCALE)

VFLB(36,48)	
Description	Quantity
#10-16 x 1/2 Phillips Stainless Screw	8
#10 x 1/2 Phillips Hex Head Screw	16
#8 x 1 Inch Self-Drilling Drywall Screw	20
Nailing Flange	4

VFLB(60,72)	
Description	Quantity
#4 x 3/8" Phillips Pan Head Screw	4
#10 x 1/2" Phillips Hex Head Screw	14
#8 x 1 Inch Self-Drilling Drywall Screw	9
Nailing Flange	4

See Parts Lists on pages 57, 59 and 61 for replacement parts. Do not order batteries, bolts, screws, washers or nuts. They are standard hardware items and available at any local hardware store.

# PRODUCT SPECIFICATIONS

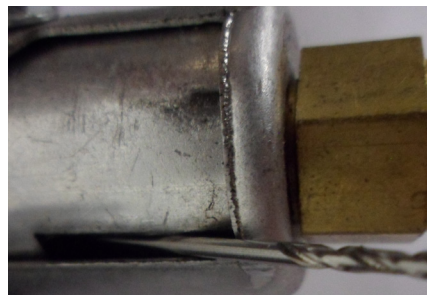
VFLB(36,48) MODELS					
Model	Gas Type	Valve Type	Orifice	Input BTU Per Hour Maximum	Input BTU Per Hour Minimum
VFLB36FP30N	Natural	Millivolt	#40	28,000	19,000
VFLB36FP30P	Propane	Millivolt	1.55mm	28,000	22,000
VFLB36FP90N	Natural	Intermittent Pilot	#40	28,000	19,000
VFLB36FP90P	Propane	Intermittent Pilot	1.55mm	28,000	22,000
VFLB48FP30N	Natural	Millivolt	#36	32,000	21,000
VFLB48FP30P	Propane	Millivolt	1.65mm	32,000	23,000
VFLB48FP90N	Natural	Intermittent Pilot	#36	32,000	21,000
VFLB48FP90P	Propane	Intermittent Pilot	1.65mm	32,000	23,000

VFLB(60,72) MODELS					
Model	Gas Type	Valve Type	Orifice	Input BTU Per Hour Maximum	Input BTU Per Hour Minimum
VFLB60FP90N	Natural	Intermittent Pilot	#32	40,000	27,000
VFLB60FP90P	Propane	Intermittent Pilot	1.8mm	38,500	30,000
VFLB72FP90N	Natural	Intermittent Pilot	#32	40,000	27,000
VFLB72FP90P	Propane	Intermittent Pilot	1.8mm	38,500	30,000

GAS SUPPLY PRESSURES (Inches Water Column)				
Gas Type	Valve Type	Maximum	Minimum	Manifold
Natural	Millivolt	10.5	7.0	3.5
Natural	Intermittent Pilot	10.5	7.0	3.5
Propane	Millivolt	13.0	11.0	10.0
Propane	Intermittent Pilot	13.0	11.0	10.0

**NOTICE:** Air shutter settings are factory set and may not be altered.

AIR SHUTTERS	
Model	Air Shutter Opening
VFLB(36,48)FP(30,90)N	1/8 inch
VFLB(36,48)FP(30,90)P	Fully Open
VFLB(60,72)FP90N	1/16 inch
VFLB60FP90P	5/16 inch
VFLB72FP90P	1/4 inch



(Measure opening using drill bit.) Set air shutter opening using suitable round object such as a drill bit. The object should barely slide between the opening.

Figure 1

# HOMEOWNER REFERENCE INFORMATION

We recommend that you record the following information about your fireplace.

Model Number: \_\_\_\_\_ Date purchased: \_\_\_\_\_

Serial Number: \_\_\_\_\_ Location of fireplace: \_\_\_\_\_

Dealer Name: \_\_\_\_\_ Dealer Phone: \_\_\_\_\_

Notes: \_\_\_\_\_



**Add Serial Number Sticker Here**

# ACCESSORIES - VFLB(36,48)

## ACCESSORIES FOR VFLB(36,48)FP30 (MILLIVOLT) MODELS

PART NUMBER	DESCRIPTION
FRBTC	Battery Operated Remote Control with Thermostat
FRBTP	Battery Operated Programmable Remote Control
TRW	Remote Wall Thermostat (Wireless)

PART NUMBER		DESCRIPTION
VFLB36FP	VFLB48FP	
DF361VBL	DF481VBL	Decorative Front, Beveled, 3/4 inch, Black
DF362VBL	DF482VBL	Decorative Front, Beveled, 1 1/2 inch, Black
VBP36LKR	VBP48LBKR	Liner with Burner Cover - Black Reflective
VBP36LWR	VBP48LBWR	Liner with Burner Cover - White Reflective
VBP36LSS	VBP48LSS	Liner – Stainless Steel
* HMFA	HMFA	External Forced Air Management System
* HMFA36P	HMFA48P	Vent-Free Heat Transfer Kit
HMFA36BL	HMFA48BL	Beveled Frame, Black (For Heat Transfer Kit)
LS60SHF	LS60SHF	Log Set - 22 Piece
DG1GC	DG1GC	Decorative Glass Droplets - 1/2 inch Glacier Ice (One kit per one square foot)
DG1SL	DG1SL	Decorative Glass Droplets - 1/2 inch Sangria Luster (One kit per one square foot)
DG1NXS	DG1NXS	Decorative Glass Drops - 1 inch Onyx Solid (One kit per one square foot)
DG1CLF	DG1CLF	Decorative Glass, Crushed - Clear Frost (One kit per one square foot)
DG1BKP	DG1BKP	Decorative Glass, Crushed - Black Polished (One kit per one square foot)
DG1BUC	DG1BUC	Decorative Glass, Crushed - Blue Clear (One kit per one square foot)
DG1BCR	DG1BCR	Decorative Glass, Crushed - Copper Reflective (One kit per one square foot)
DG1BZR	DG1BZR	Decorative Glass, Crushed - Bronze Reflective (One kit per one square foot)
DR1FMA	DR1FMA	Decorative Rock, Ceramic Fiber – Medium (One kit per one square foot)
DRFPA	DRFPA	Decorative Rock, Ceramic Fiber - Pebble (One kit per 1/2 square foot)
LK5	LK5	120V Lighting Kit – Requires Switch or Rheostat

**NOTICE:** The total burner cover area for decorative glass or rocks equals 1.75 square feet for VFLB36FP and 2.25 square feet for VFLB48FP. Decorative Glass Droplets can be mixed with crushed glass. One box of crushed glass covers 1 sq. ft. Glass colors can be mixed.

**NOTICE:** Never place decorative media material on or next to the burner. Decorative glass or rocks should not be higher than the lip of the burner cover.

**NOTICE:** If installing a decorative front, an offset between the finishing materials and fireplace opening is required. Refer to pages 29 and 31 as well as the installation instructions provided with the decorative front for more information.

\* Must be purchased together.

# ACCESSORIES - VFLB(60,72)

REQUIRED ACCESSORIES		
Accessories For - VFLB(60,72)FP90(N,P)-1		
PART NUMBER		DESCRIPTION
VFLB60	VFLB72	
DG1CLF	DG1CLF	Decorative Glass, Crushed - Clear Frost (One kit per one square foot) Recommended
DG1BKP	DG1BKP	Decorative Glass, Crushed - Black Polished (One kit per one square foot)
DG1BUC	DG1BUC	Decorative Glass, Crushed - Blue Clear (One kit per one square foot)
DG1BCR	DG1BCR	Decorative Glass, Crushed - Copper Reflective (One kit per one square foot)
DG1BZR	DG1BZR	Decorative Glass, Crushed - Bronze Reflective (One kit per one square foot)

**NOTICE:** Decorative crushed glass is required for installation. Clear Frost is recommended. Decorative = Glass Droplets can be mixed with crushed glass, but cannot be substituted for crushed glass. One box of crushed glass covers 1 sq. ft. Glass colors can be mixed, and transparent and translucent crushed glass makes LED lights more visible.

**NOTICE:** Requires five square feet for VFLB60, six square feet for VFLB72.

**NOTICE:** Never place decorative media material on or next to the burner.

OPTIONAL ACCESSORIES		
Accessories For - VFLB(60,72)FP90(N,P)-1		
PART NUMBER		DESCRIPTION
VFLB60	VFLB72	
DF601VBL	DF721VBL	Decorative Front, Beveled, 3/4 inch, Black
DF602VBL	DF722VBL	Decorative Front, Beveled, 1 1/2 inch, Black
VBP60LKR	VBP72LKR	Liner - Black Reflective Glass
VBP60LSS	VBP72LSS	Liner - Stainless Steel
HMFA	HMFA	External Forced Air Management System
HMFA60P	HMFA72P	Vent-Free Heat Transfer Kit
HMFA60BL	HMFA72BL	Beveled Frame, Black (For Heat Transfer Kit)
LS60DF	LS72DF	Log Set
DG1GC	DG1GC	Decorative Glass Droplets - 1/2 inch Glacier Ice (Used as accent only)
DG1SL	DG1SL	Decorative Glass Droplets - 1/2 inch Sangria Luster (Used as accent only)
DG1NXS	DG1NXS	Decorative Glass Drops - 1 inch Onyx Solid (Used as accent only)
DRFPA	DRFPA	Decorative Rock, Ceramic Fiber - Pebble (Used as accent only)

**NOTICE:** If installing a decorative front, an offset between the finishing materials and fireplace opening is required. Refer to pages 29 and 31 as well as the installation instructions provided with the decorative front for more information.

\* Must be purchased together.

# INTRODUCTION

## INSTRUCTIONS TO INSTALLER

1. Leave instruction manual with owner after installation.
2. Have owner register online or fill out and mail the Product Registration Card supplied with the unvented fireplace.
3. Fill out Homeowner Reference Information on page 7.
4. Show homeowner how to start and operate the fireplace.
5. Show homeowner basic maintenance.

Consult the local Building Department regarding regulations, codes or ordinances which apply to the installation of an unvented fireplace.

This fireplace may be installed in an aftermarket\* manufactured (mobile) home, where not prohibited by state or local codes.

\*Aftermarket: Completion of sale, not for purpose of resale, from the manufacturer.

## WELL HEAD GAS INSTALLATIONS

Some natural gas utilities use "well head" gas. This may affect the Btu output of the unit and promote sooting. Units shall not be converted to use well head gas.

This appliance is only for use with the type of gas indicated on the rating plate. This appliance is not convertible for use with other gases.

### WARNING

**Any change to this fireplace or its controls can be dangerous. Improper installation or use of the fireplace can cause serious injury or death from fire, burns, explosion or carbon monoxide poisoning.**

This fireplace is intended for supplemental heating.

Any alteration of the original design, installed other than as shown in these instructions or use with a type of gas not shown on the rating plate is the responsibility of the person and company making the change.

## IMPORTANT

All correspondence should refer to complete Model Number, Serial Number and type of gas. (See page 7.)

### WARNING

**This appliance is equipped for natural or propane gas. Field conversion is not permitted.**

During manufacture, this fireplace is treated with oils, films and bonding agents. These are not harmful but may produce smoke and odor as they burn off during initial operation. This is normal. Open window to vent any smoke or odor.

## INSTALLATION ON RUGS AND TILE

If this fireplace is installed directly on carpeting, tile or other combustible material other than wood flooring the fireplace shall be installed on a metal or wood panel extending the full width and depth of the fireplace.

## QUALIFIED INSTALLING AGENCY

Installation and replacement of gas piping, gas utilization equipment or accessories and repair and servicing of equipment shall be performed only by a qualified agency.

The term qualified agency means any individual, firm, corporation or company which either in person or through a representative is engaged in and is responsible for (a) the installation or replacement of gas piping or (b) the connection, installation, repair or servicing of equipment, who is experienced in such work, familiar with all precautions required and has complied with all the requirements of the authority having jurisdiction.

**Commonwealth of Massachusetts:** The installation must be made by a licensed plumber or gas fitter in the Commonwealth of Massachusetts.

Sellers of unvented propane or natural gas-fired supplemental fireplaces shall provide to each purchaser a copy of 527 CMR 30 upon sale of the unit.

In the Commonwealth of Massachusetts, unvented propane and natural gas-fired space heaters shall be prohibited in bedrooms and bathrooms.

The installation must conform with local codes or, in the absence of local codes, with the National Fuel Gas Code, ANSI Z223.1.\* / NFPA 54.

\*Available from the American National Standards Institute, Inc. 1430 Broadway, New York, N.Y. 10018.

### WARNING

**Failure to keep the primary air opening(s) of the burner(s) clean may result in sooting and property damage.**

## FOR THE INSTALLER

- Installation and repair should be done by a qualified service person. The fireplace should be inspected before use and at least annually by a qualified service person. More frequent cleaning might be required due to excessive lint from carpeting, bedding material, etc. It is imperative that control compartments, burners and circulating air passageways of the fireplace be kept clean. Keep burner and control compartment clean.
- An unvented room fireplace having an input rating of more than 6,000 Btu per hour shall not be installed in a bathroom
- An unvented room fireplace having an input rating of more than 10,000 Btu per hour shall not be installed in a bedroom or bathroom.
- Use Non-Combustible Materials where indicated for the fireplace installation. Non-combustible material do not ignite or burn as a result of using the fireplace. These include metal, brick, ceramic, concrete, slate, glass, and plaster. Adhesives must be rated for high temperatures. Any mechanical fasteners used to install material must also be non-combustible, including wall anchors and tile spacers. Materials that pass the ASTM E 136 test (Standard Test Method for Behavior of Materials in a Vertical Tube Furnace at 750C) are considered non-combustible.
- Install the fireplace out of household traffic and away from furniture and draperies. The high temperatures produced by the fireplace create an ignition risk.

# IMPORTANT INFORMATION

## **⚠ WARNING**

**Read and follow these safety precautions prior to operating this appliance. Failure to follow these precautions may result in death, injury, or property damage.**

All correspondence should refer to complete Model Number, Serial Number and type of gas. Fill out the Homeowner Reference Section on page 7 in installation manual.

### **FOR THE HOMEOWNER**

- Do not allow Combustible Materials adjacent to or in contact with the fireplace. Combustible materials include wood, compressed paper, plant fibers, or other materials that will burn. These materials are considered combustible even when treated with fire-retardant chemicals.
- Alert children and adults to the hazards of high surface temperatures. Warn them to stay away to avoid burns and clothing ignition.
- Supervise children when they are in the same room as the fireplace.
- Do not place clothing or other flammable material on or near the fireplace.
- Any safety screen or guard removed for servicing the fireplace must be replaced prior to operating the fireplace.
- Keep fireplace area clear and free from combustible materials, gasoline and other flammable vapors and liquids.
- Do not use this fireplace if any part has been under water. Immediately call a qualified service technician to inspect the fireplace and to replace any part of the control system and any gas control which has been under water.
- Operate fireplace with all glass panels and barrier screen in place.
- Do not place embers (rock wool) in this fireplace.
- Do not place lava rocks in this fireplace.

## **⚠ WARNING**

**This fireplace is not for use with solid fuels. Improper use of the fireplace can cause serious injury or death from fire, burns, explosions or carbon monoxide poisoning.**

### **MILLIVOLT 3 SERIES ONLY 750 MILLIVOLT SYSTEM**

When igniting the pilot, the thermocouple produces millivolts (electrical current) which energizes the magnet in the gas valve. After 30 seconds to 1 minute time period, release the gas control knob and the pilot will stay ON. Allow pilot flame to operate an additional one to two minutes before turning the gas control knob from the PILOT position to the ON position. This time period allows the millivolts (electrical energy) to build-up to a sufficient level allowing the gas control to operate properly.

### **MAINTENANCE AND SERVICE**

Although the frequency of servicing and maintenance will depend on use and the type of installation, a qualified service technician should perform an appliance checkup at the beginning of each heating season. Specific guidelines regarding each appliance maintenance task are listed below.

**NOTICE:** It is normal for steel appliances to make expansion and/or contraction noise during the start-up or cool-down cycle. Similar noises are found with a furnace heat exchanger or car engine.

**NOTICE:** During manufacture, components of this fireplace insert are treated with oils, films or bonding agents. These are not harmful, but may produce smoke and smells as they are burned off during the initial operation of the fireplace insert. This is normal. Open a window to ventilate the area.

Only glass approved for use by the manufacturer in fireplace may be used for replacement. The glass replacement must be done by a licensed or qualified service person.

## **⚠ WARNING**

- **Avoid breaking the glass.**
- **Do not operate this appliance without the glass panel and barrier screen, or with a broken glass panel.**
- **Replace only with Empire Comfort Systems parts.**

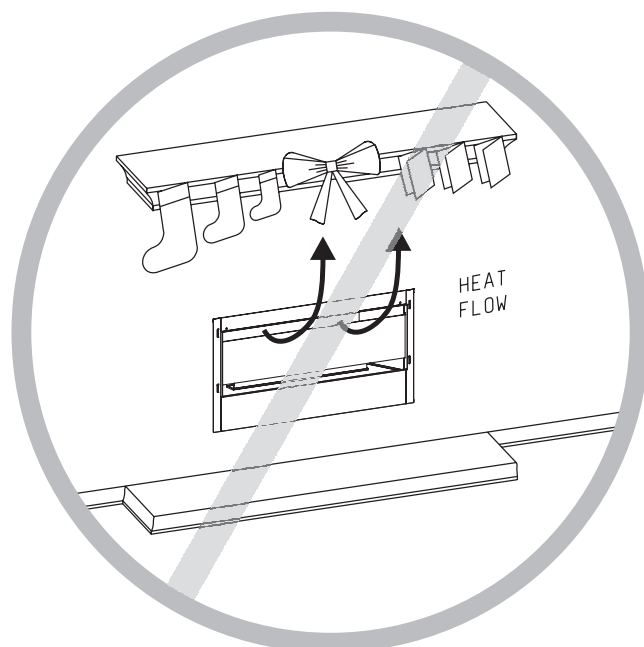
## **⚠ CAUTION**

**Do not use Ammonia-based or abrasive cleaners on glass. To prevent etching or discoloring, clean the glass with Fireplace Glass Cleaner (available from the dealer). Do not attempt to clean glass when glass is hot.**

### **COMBUSTIBLE MATERIAL**

## **⚠ WARNING**

**Do not attach combustible material to the mantel of your fireplace. This is a fire hazard.**



**Figure 2**

# IMPORTANT SAFETY INFORMATION

## **⚠ WARNING**

When used without adequate combustion and ventilation air, appliance may give off CARBON MONOXIDE, an odorless, poisonous gas.

Do not install appliance until all necessary provisions are made for combustion and ventilation air. Consult the written instructions provided with the appliance for information concerning combustion and ventilation air. In the absence of instructions, refer to the National Fuel Gas Code, ANSI Z223.1/NFPA 54, Air for Combustion and Ventilation, or applicable local codes.

This appliance is equipped with a PILOT LIGHT SAFETY SYSTEM designed to turn off the appliance if not enough fresh air is available.

The pilot light safety system senses the depletion of oxygen at its location. If this fireplace is installed in a structure having a high vertical dimension, the possibility exists that the oxygen supply at the higher levels will be less than that at the fireplace. In this type of application, a fan to circulate the structure air will minimize this effect. The use of this fan will also improve the comfort level in the structure. When a fan is used to circulate air, it should be located so that the air flow is not directed at the burner.

**DO NOT TAMPER WITH PILOT LIGHT SAFETY SYSTEM!**

If fireplace shuts off, do not relight until you provide fresh air.

If fireplace keeps shutting off, have it serviced. Keep burner and control compartment clean. See installation and operating instructions.

## **⚠ WARNING**

**CARBON MONOXIDE POISONING MAY  
LEAD TO DEATH.**

Early signs of carbon monoxide poisoning resemble the flu, with headache, dizziness and/or nausea. If you have these signs, fireplace may not be working properly. Get fresh air at once! Have fireplace serviced.

Some people — pregnant women, persons with heart or lung disease, anemia, those under the influence of alcohol, those at high altitudes — are more affected by carbon monoxide than others.

## **⚠ DANGER**

The installer is responsible for the verifying the correct position of the air shutter and adjusting it if required. If not adjusted to the proper opening, a fire, explosion, or production of carbon monoxide may result causing property damage, personal injury or loss of life.

## **⚠ DANGER**

The installer is responsible for testing all connections for gas leaks. A gas leak will create a situation where a fire, explosion, or production of carbon monoxide may result causing property damage, personal injury or loss of life.

## **⚠ WARNING**

Do not use a blower insert, heat exchanger insert or other accessory not approved for use with this heater. The use of accessories not tested and approved for use with this fireplace will create a situation where a fire, explosion, or production of carbon monoxide may result causing property damage, personal injury or loss of life.

## **⚠ WARNING**

This fireplace needs fresh air for ventilation to run properly. Inadequate air supply may create a situation where a fire, explosion, or production of carbon monoxide may result causing property damage, personal injury or loss of life. This fireplace has an ODS (oxygen depletion sensor) which will shut down the fireplace if adequate fresh air is not available. See troubleshooting section in the instructions.

## **⚠ WARNING**

Do not operate this fireplace unless all components including burners and controls are in good working condition. Never operate this fireplace if any optional log or twig is broken. Replacement components are available through your local dealer as indicated in the How to Order Repair Parts section of the fireplace manual. See Page 47.

## **⚠ WARNING**

**"FIRE, EXPLOSION, AND ASPHYXIATION HAZARD**  
Improper adjustment, alteration, service, maintenance or installation of this heater or its controls can cause death or serious injury.

Read and follow instructions and precautions in User's Information Manual provided with this heater."

# SAFETY INFORMATION FOR USERS OF PROPANE GAS

Propane is a flammable gas which can cause fires and explosions. In its natural state, propane is odorless and colorless. You may not know all the following safety precautions which can protect both you and your family from an accident. Read them carefully now, then review them point by point with the members of your household.

Someday when there may not be a minute to lose, everyone's safety will depend on knowing exactly what to do. If, after reading the following information, you feel you still need more information, please contact your gas supplier.

## PROPANE GAS WARNING ODOR

**If a gas leak happens, you should be able to smell the gas because of the odorant put in the Propane Gas. That's your signal to go into immediate action!**

- Do not operate electric switches, light matches, use your phone. Do not do anything that could ignite the gas.
- Get everyone out of the building, vehicle, trailer, or area. Do that IMMEDIATELY.
- Close all gas tank or cylinder supply valves.
- Propane Gas is heavier than air and may settle in low areas such as basements. When you have reason to suspect a gas leak, keep out of basements and other low areas. Stay out until firefighters declare them to be safe.
- Use your neighbor's phone and call a trained Propane Gas service person and the fire department. Even though you may not continue to smell gas, do not turn on the gas again. Do not re-enter the building, vehicle, trailer, or area.
- Finally, let the service man and firefighters check for escaped gas. Have them air out the area before you return. Properly trained Propane Gas service people should repair the leak, then check and relight the gas appliance for you.

## NO ODOR DETECTED - ODOR FADE

**Some people cannot smell well. Some people cannot smell the odor of the chemical put into the gas. You must find out if you can smell the odorant in propane.** Smoking can decrease your ability to smell. Being around an odor for a time can affect your sensitivity or ability to detect that odor. Sometimes other odors in the area mask the gas odor. People may not smell the gas odor or their minds are on something else. Thinking about smelling a gas odor can make it easier to smell.

**The odorant in Propane Gas is colorless, and it can fade under some circumstances.** For example, if there is an underground leak, the movement of the gas through soil can filter the odorant. Odorants in Propane Gas also are subject to oxidation.

This fading can occur if there is rust inside the storage tank or in iron gas pipes. The odorant in escaped gas can adsorb or absorb onto or into walls, masonry and other materials and fabrics in a room. That will take some of the odorant out of the gas, reducing its odor intensity.

Propane Gas may stratify in a closed area, and the odor intensity could vary at different levels. Since it is heavier than air, there may be more odor at lower levels. Always be sensitive to the slightest gas odor. If you detect any odor, treat it as a serious leak. Immediately go into action as instructed earlier.

## SOME POINTS TO REMEMBER

- **Learn to recognize the odor of Propane Gas.** Your local Propane Gas Dealer can give you a "Scratch and Sniff" pamphlet. Use it to find out what the propane odor smells like. If you suspect that your Propane Gas has a weak or abnormal odor, call your Propane Gas Dealer.
- If you are not qualified, do not light pilot lights, perform service, or make adjustments to appliances on the Propane Gas system. If you are qualified, consciously think about the odor of Propane Gas prior to and while lighting pilot lights or performing service or making adjustments.
- Sometimes a basement or a closed-up house has a musty smell that can cover up the Propane Gas odor. Do not try to light pilot lights, perform service, or make adjustments in an area where the conditions are such that you may not detect the odor if there has been a leak of Propane Gas.
- Odor fade, due to oxidation by rust or adsorption on walls of new cylinders and tanks, is possible. Therefore, people should be particularly alert and careful when new tanks or cylinders are placed in service. Odor fade can occur in new tanks, or reinstalled old tanks, if they are filled and allowed to set too long before refilling.
- Cylinders and tanks which have been out of service for a time may develop internal rust which will cause odor fade. If such conditions are suspected to exist, a periodic sniff test of the gas is advisable. **If you have any question about the gas odor, call your Propane Gas Dealer. A periodic sniff test of the Propane Gas is a good safety measure under any condition.**
- If, at any time, you do not smell the Propane Gas odorant and you think you should, assume you have a leak. Then take the same immediate action recommended above for the occasion when you do detect the odorized Propane Gas.
- If you experience a complete "gas out," (the container is under no vapor pressure), turn the tank valve off immediately. If the container valve is left on, the container may draw in some air through openings such as pilot light orifices. If this occurs, some new internal rusting could occur. If the valve is left open, then treat the container as a new tank. Always be sure your container is under vapor pressure by turning it off at the container before it goes completely empty or having it refilled before it is completely empty.

# IMPORTANT INSTALLATION GUIDELINES

## PROPER PRIMARY AIRFLOW INTO BURNER

For proper burner operation and flame appearance, the flow of primary air into the venturi tube, located at the gas inlet of the burner, must not be reduced. This flow of air is reduced if dirt, lint or other obstructions build-up around or inside the venturi. Any obstruction in the venturi tube area must be removed. The flow of air into the venturi is also reduced if the gas orifice isn't centered in the venturi inlet and/or is not aligned with the venturi. Any misalignment of the burner orifice may be corrected by bending the shutter cap holding the orifice to the inlet of the venturi tube.

## CEILING FANS, PORTABLE FANS OR LOGS INSTALLED NEAR COLD AIR RETURNS

Ceiling fans or oscillating floor type fans need to be monitored during the operation of a vent-free fireplace. If the air blows directly into the flame causing it to disrupt the flame, it should be turned off or redirected. Ceiling fans could be reversed to possibly eliminate flame impingement, and the floor fan should be redirected. Upon installation, be aware of any cold air returns or vents in the proximity of the fireplace. Any draft created around a vent-free fireplace can cause the flame to impinge on the logs or decorative media and create a sooting situation.

## TELEVISION CONSIDERATIONS

Installing a television above a fireplace has become increasingly popular; however, the area above any fireplace gets hot and most TV manufacturers recommend against placing their products near a heat source.

If a television is installed above this fireplace, Empire Comfort Systems accepts no responsibility for damage or injuries. Follow the television manufacturer's installation instructions, including any recommendations regarding proximity to heat sources.

If a TV is installed above the fireplace, turn off the fireplace and let it cool completely before servicing or touching any buttons on the TV.

## NOTICE FOR FINISHING MATERIALS

Due to the variable properties of natural stone, the material may have stress points that are unpredictable when installed above or around the fireplace. These stress points may result in cracking of the finish materials. Empire Comfort Systems is not responsible for the finishing materials used with our fireplaces.

# WATER VAPOR: A BY-PRODUCT OF UNVENTED ROOM HEATERS

Water vapor is a by-product of gas combustion. An unvented room heater produces approximately one ounce (30ml) of water for every 1,000 BTU (.3KW's) of gas input per hour.

Unvented room heaters are recommended as supplemental heat (a room) rather than a primary heat source (an entire house). In most supplemental heat applications, the water vapor does not create a problem, but helps correct the low humidity atmosphere experienced during cold weather.

The following steps will help ensure that water vapor does not become a problem.

1. Be sure the heater is sized properly for the application, including ample combustion air and circulation air.
2. If high humidity is experienced, a dehumidifier will help lower the water vapor content of the air.
3. Do not use an unvented room heater as the primary heat source.

# PROVISIONS FOR ADEQUATE COMBUSTION & VENTILATION AIR

This heater shall not be installed in a confined space unless provisions are provided for adequate combustion and ventilation air.

The National Fuel Gas Code defines a confined space as a space whose volume is less than 50 cubic feet per 1,000 Btu per hour (4.8 m<sup>3</sup> per kw) of the aggregate input rating of all appliances installed in that space and an unconfined space as a space whose volume is not less than 50 cubic feet per 1,000 Btu per hour (4.8 m<sup>3</sup> per kw) of the aggregate input rating of all appliances installed in that space. Rooms communicating directly with the space in which the appliances are installed, through openings not furnished with doors, are considered a part of the unconfined space.

## UNUSUALLY TIGHT CONSTRUCTION

The air that leaks around doors and windows may provide enough fresh air for combustion and ventilation. However, in buildings of unusually tight construction, additional fresh air must be provided.

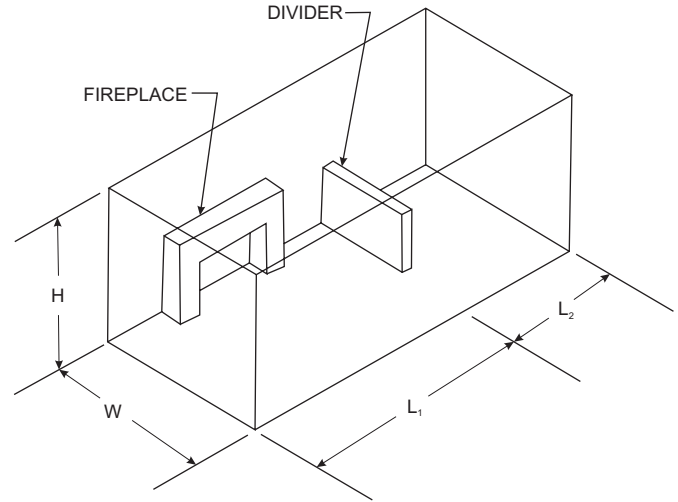
**Unusually tight construction is defined as construction where:**

- Walls and ceilings exposed to the outside atmosphere have a continuous water vapor retarder with a rating of one perm or less with any openings gasketed or sealed, and
- Weatherstripping has been added on openable windows and doors, and
- Caulking or sealants are applied to areas such as joints around window and door frames, between sole plates and floors, between wall-ceiling joints, between wall panels, at penetrations for plumbing, electrical, and gas lines, and at other openings.

If the home meets all three criteria above, additional fresh air must be provided.

### **⚠ WARNING**

**If the area in which the heater may be operated is smaller than that defined as an unconfined space or if the building is of unusually tight construction, provide adequate combustion and ventilation air by one of the methods described in the *National Fuel Gas Code, ANSI Z223.1/NFPA 54, Air for Combustion and Ventilation*, or applicable local codes.**



Example of Large Room with 1/2 Wall divider.

**Figure 3**

The following formula can be used to determine the maximum heater rating per the definition of unconfined space:

$$\text{Btu/Hr} = \frac{(L_1 + L_2)\text{FT} \times (W)\text{FT} \times (H)\text{FT}}{50} \times 1000$$

If the area in which the heater may be operated is smaller than that defined as an unconfined space, provide adequate combustion and ventilation air by one of the methods described in the National Fuel Gas Code, ANSI Z223.1, NFPA54.

Adhere to all codes, or in their absence, the latest edition of THE NATIONAL FUEL GAS CODE ANSI Z223.1/NFPA54 which can be obtained from:

American National Standards Institute National Fire Protection Association, Inc.

11 West 42nd St.  
New York, NY 10018

Batterymarch Park  
Quincy, MA 02269

# PROVISIONS FOR ADEQUATE COMBUSTION & VENTILATION AIR

If the area in which the heater will be operated is smaller than that defined as an unconfined space, provide adequate combustion and ventilation air by one of the following methods:

1. Add the space of an adjoining room, and rework the equation. If doing so creates an unconfined space, remove door to adjoining room or add ventilation grills between rooms. See **Ventilation Air From Inside Building**.
2. Vent room directly to the outdoors. See **Ventilation Air From Outdoors**.
3. Install a lower Btu per hour heater, if lower Btu per hour size makes room unconfined.

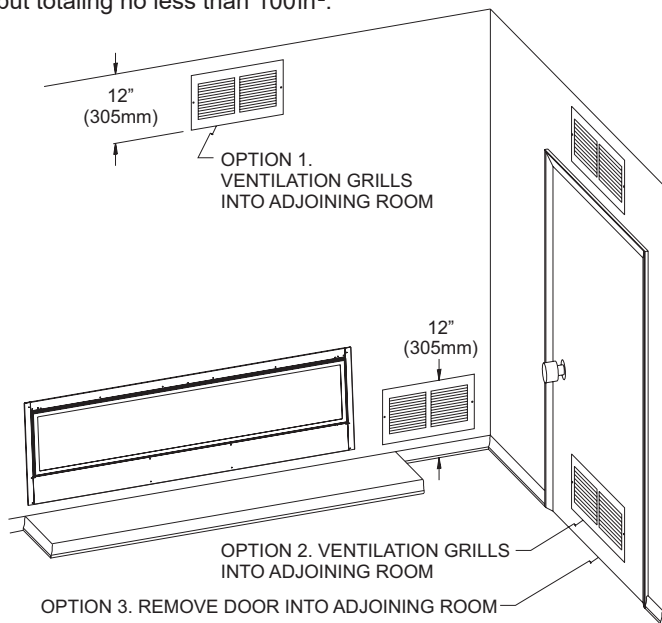
If the actual Btu per hour used is less than the maximum Btu per hour the space can support, the space is an unconfined space. No additional fresh air ventilation is needed.

## ⚠ WARNING

**Additional ventilation air must be provided in a confined space.**

### Ventilation Air From Inside Building

This fresh air would come from an adjoining unconfined space. When ventilating to an adjoining unconfined space, two permanent openings must be provided; one within 12" of the ceiling and one within 12" of the floor on the wall connecting the two spaces. See **Options 1 and 2, Figure 4**. Door(s) into adjoining room may also be removed. See **option 3, Figure 4**. Each ventilation grill or opening shall have a minimum free area of one square inch per 1,000 BTUH of the total input rating of the gas equipment in the confined space, but totaling no less than 100in<sup>2</sup>.



**Figure 4**

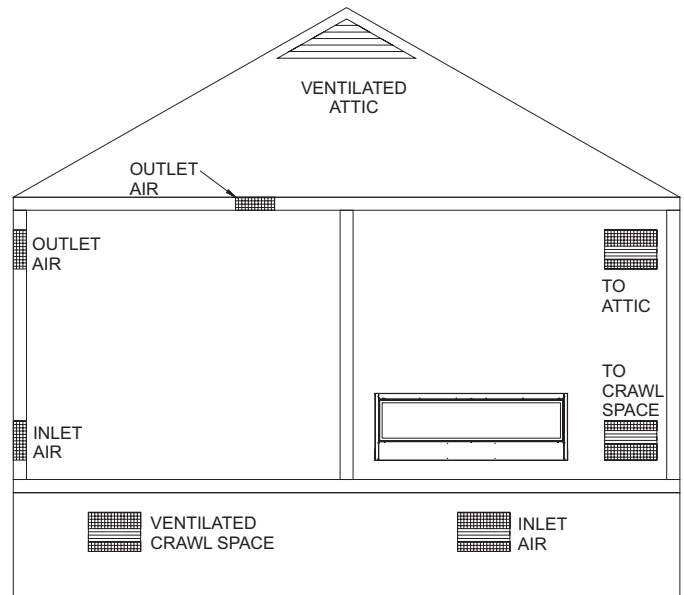
## ⚠ WARNING

**When adding adjoining spaces, the combined spaces must have enough fresh air to supply all appliances in both spaces.**

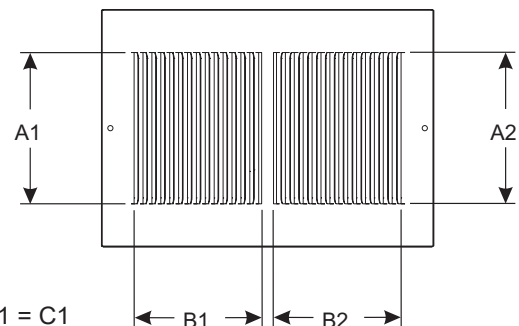
### Ventilation Air From Outdoors

Provide extra fresh air by using ventilation grills or ducts. Two permanent openings must be provided; one within 12" of the ceiling and one with 12" of the floor. Connect these items directly to the outdoors or spaces open to the outdoors. These spaces include attics and crawl spaces. For direct communication with the outdoors through a vertical duct, each grill shall have a free area opening of one square inch per 4,000 BTU/Hr of heater input rating. If a horizontal duct is used, each grill opening shall have a free area of one square inch per 2,000 BTU/Hr. Follow the *National Fuel Code ANSI Z223.1/NFPA54, Air for Combustion and Ventilation* for required size of ventilation grills or ducts.

**IMPORTANT:** Do not provide openings for inlet or outlet air into attic if attic has a thermostat-controlled power vent. Heated air entering the attic will activate the power vent.



**Figure 5**



$$A1 \times B1 = C1$$

$$A2 \times B2 = C2$$

$$C1 + C2 = \text{Sq. In. Required}$$

**Example:** For a 30,000 BTU Heater, 1 sq. in. per 1,000 BTU equals 30 sq. in. of opening.

$$(A1) 5\text{in}^2 \times (B1) 3\text{in}^2 = (C1) 15\text{in}^2$$

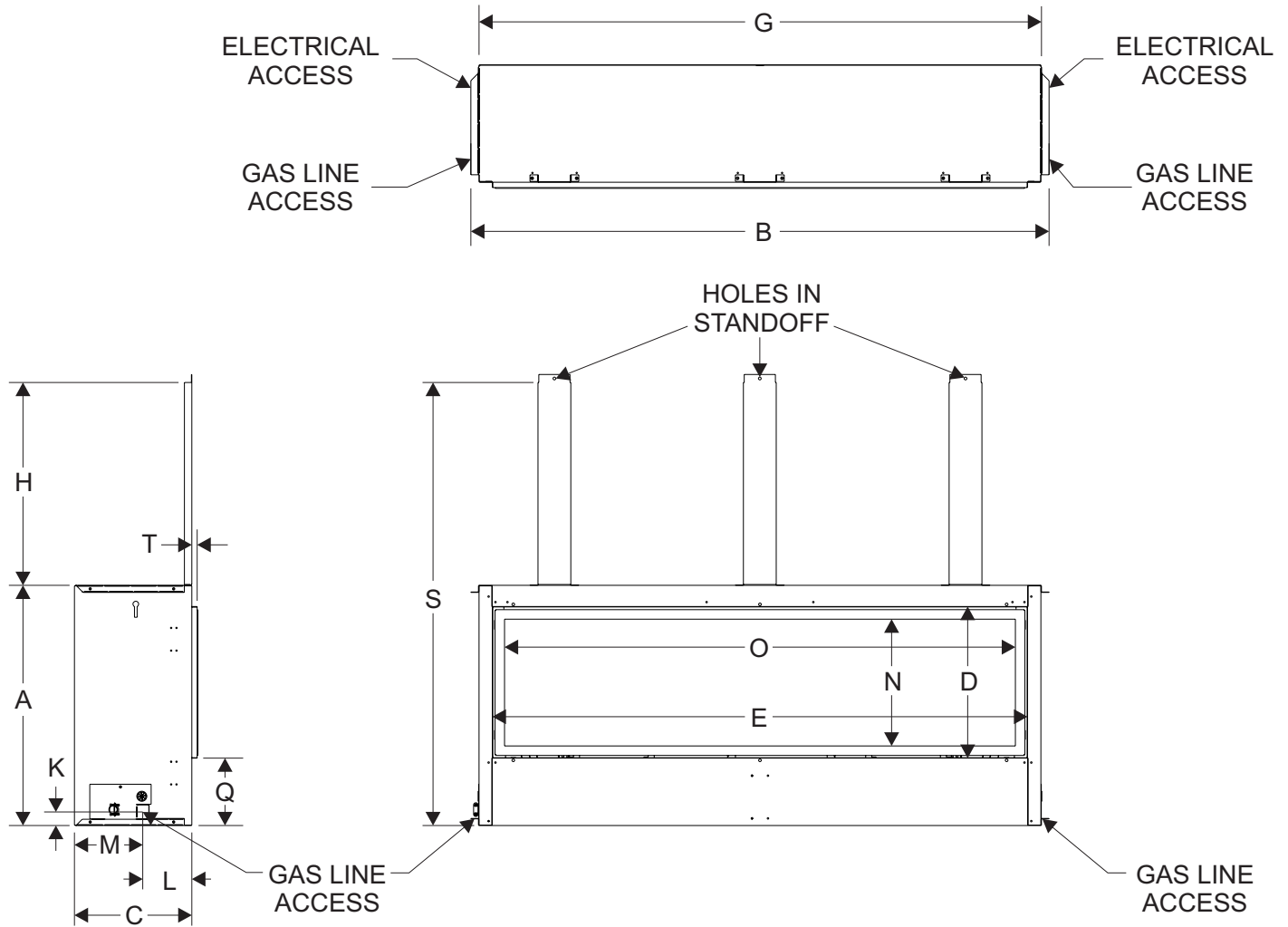
$$(A2) 5\text{in}^2 \times (B2) 3\text{in}^2 = (C2) 15\text{in}^2$$

$$(C1) 15\text{in}^2 + (C2) 15\text{in}^2 = 30\text{in}^2$$

**NOTE:** When measuring B1 and B2, the cumulative total of louver thicknesses shall be subtracted.

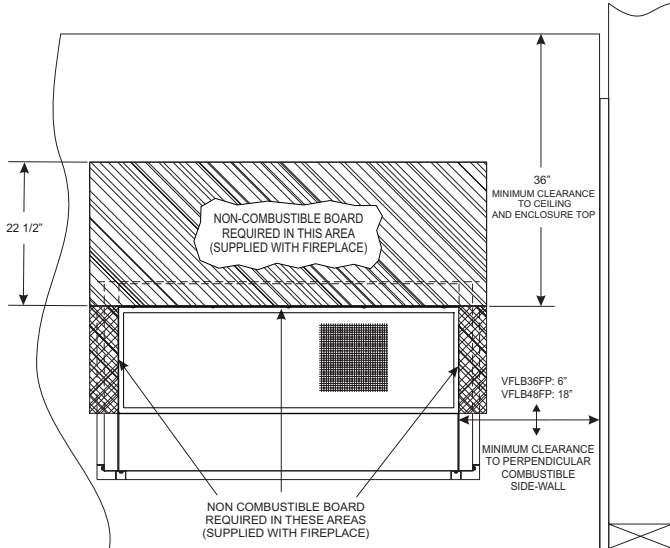
**Figure 6**

# FIREPLACE DIMENSIONS



INDEX LETTER	DIMENSION DESCRIPTION	VFLB36FP	VFLB48FP	VFLB60FP	VFLB72FP
		DIMENSIONS (In Inches)			
A	The Maximum Height Of Firebox Face (Excluding Standoffs)	22-1/2	22-1/2	22-1/2	22-1/2
B	The Maximum Width Of The Firebox Face (Excluding Nailing Flanges)	42-3/16	54-3/16	66-3/16	78-3/16
C	The Maximum Depth Of The Firebox	11	11	11-1/16	11-1/16
D	The Height Of The Firebox Opening	14-1/8	14-1/8	14-1/8	14-1/8
E	The Width Of The Firebox Opening	38-1/16	50-1/16	62-1/16	74-1/16
F	The Interior Depth Of The Firebox (Not Shown)	9-9/16	9-9/16	9-7/8	9-7/8
G	The Rear Exterior Width Of The Firebox	40-3/4	52-3/4	64-3/4	76-3/4
H	The Height To The Firebox Standoffs	19	19	19	19
K	Height From The Bottom Of The Firebox To The Gas Line Opening	1-1/4	1-1/4	1-1/4	1-1/4
L	Depth From The Front Of The Firebox To Gas Line Opening	4-9/16	4-9/16	4-9/16	4-9/16
M	Depth From Rear Of Firebox To Gas Line Opening	6-7/16	6-7/16	6-7/16	6-7/16
N	Screen Barrier Opening Height	11-7/8	11-7/8	11-7/8	11-7/8
O	Screen Barrier Opening Width	35-7/8	47-7/8	59-7/8	71-7/8
Q	Distance From Fireplace Bottom To Fireplace Opening	6-3/8	6-3/8	6-3/8	6-3/8
S	Overall Height To Header	41-1/2	41-1/2	41-1/2	41-1/2
T	Opening Lip	1/2	1/2	1/2	1/2

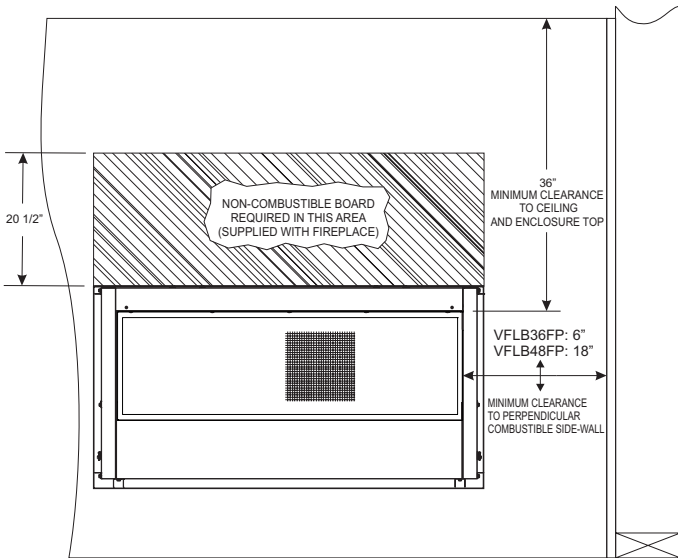
# CLEARANCES



**NOTICE:** Combustible material is allowed below a fireplace viewing area opening and outside the non-combustible board.

**NOTICE:** If installing a decorative front, an offset between the finishing materials and fireplace opening is required. Refer to page 27 for more information.

Figure 7 - Finishing Option 1



**NOTICE:** Combustible material is allowed outside of the non-combustible board and outside of the fireplace boundaries.

**NOTICE:** Non-combustible material provided with the fireplace is larger than required for this installation. Material may be trimmed to the proper size. Wear eye and breathing protection when cutting non-combustible board.

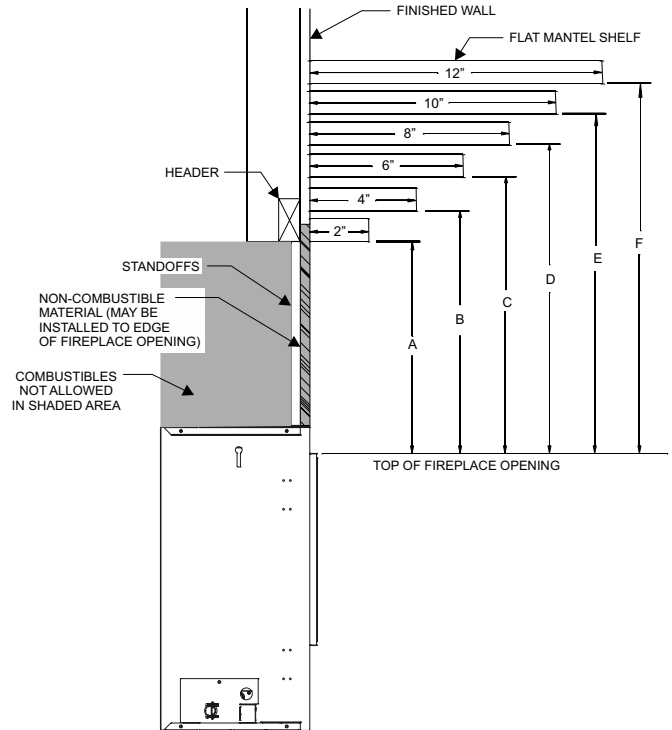
**NOTICE:** If installing a decorative front, an offset between the finishing materials and fireplace opening is required. Refer to page 31 for more information.

Figure 8 - Finishing Option 2

## WARNING

Do not put screws through large non-combustible board and into the fireplace. Attach screws only in standoffs.

## MANTEL CLEARANCES



MODEL		DIMENSIONS (In Inches)					
		A	B	C	D	E	F
VFLB36FP	VFLB60FP	18	20	22	24	26	28
VFLB48FP	VFLB72FP	18	20	22	24	26	28

Figure 9

COMBUSTIBLE MATERIALS ALLOWED IN SHADED AREA

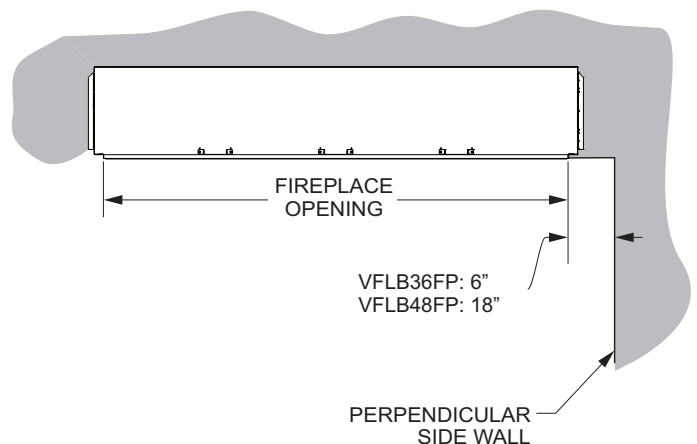
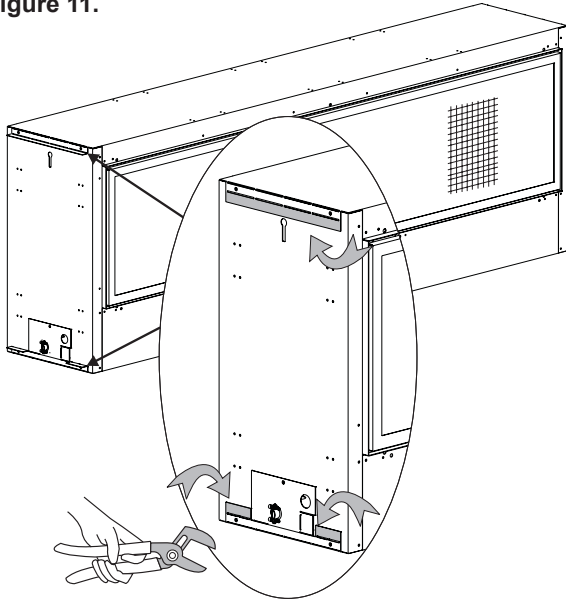


Figure 10

# ADDING NAILING FLANGES AND STANDOFF BRACKETS

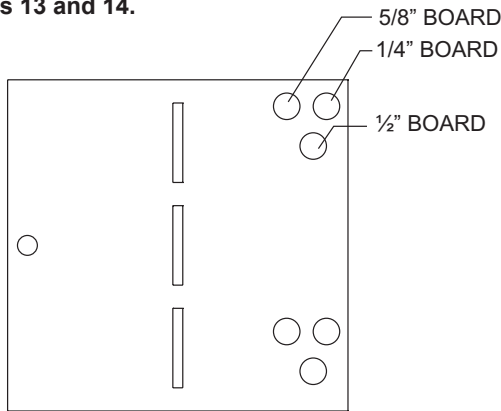
1. At the top and bottom of the fireplace, use pliers to bend each side standoff 90 degrees away from the cabinet. See **Figure 11**.



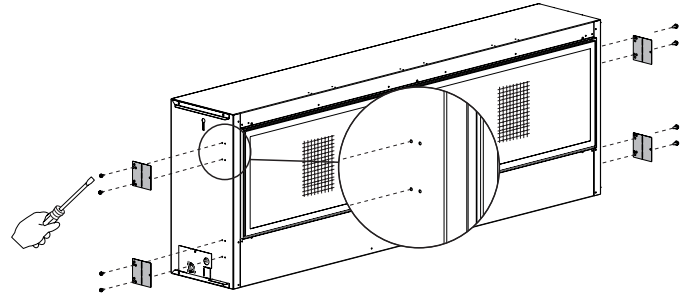
**Figure 11**

Locate the nailing flanges and standoff brackets supplied with the fireplace under the burner cover.

2. The holes in the nailing flanges allow for different thickness boards and depths of wall boards. See **Figure 12**. Install nailing flanges with two 10 x 12 screws (each) in pair of holes closer to the face of the fireplace. Leave the nailing flanges flat until after the fireplace is lifted into the framing. See **Figures 13 and 14**.



**Figure 12**

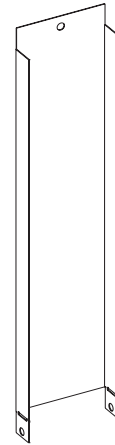


**Figure 14 - OPTION 2**

**⚠ WARNING**

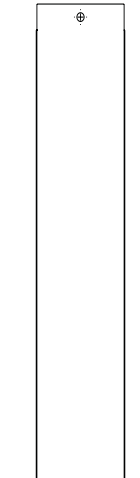
**TWO MAN LIFT RULE!**

3. Repeat on opposite side.
4. Insert fireplace into enclosure. See **Figure 14**.
5. Level fireplace.
6. Bend nailing flanges over side frames and attach.
7. Locate the steel standoff brackets under the burner cover. See **Figure 15**.

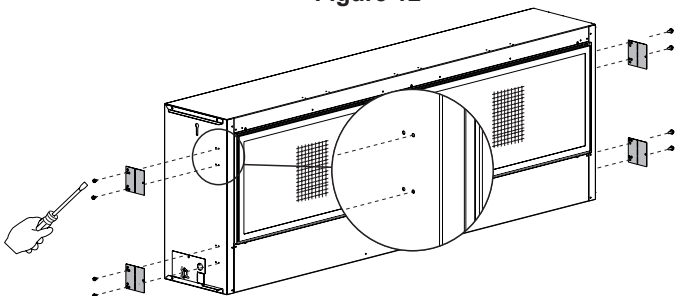


**Figure 15**

8. The brackets have a perforation at the bottom of each side. Bend them at the perforation. See **Figure 16**.



**Figure 16**



**Figure 13 - OPTION 1**

# ADDING NAILING FLANGES AND STANDOFF BRACKETS

9a. **OPTION 1** - Secure the brackets to the fireplace top with screws. There are holes located in the top of the fireplace for each standoff bracket. The holes closer to the front edge of the fireplace are for mounting non-combustible board around the opening. **Finishing OPTION 1. See Figure 17.**

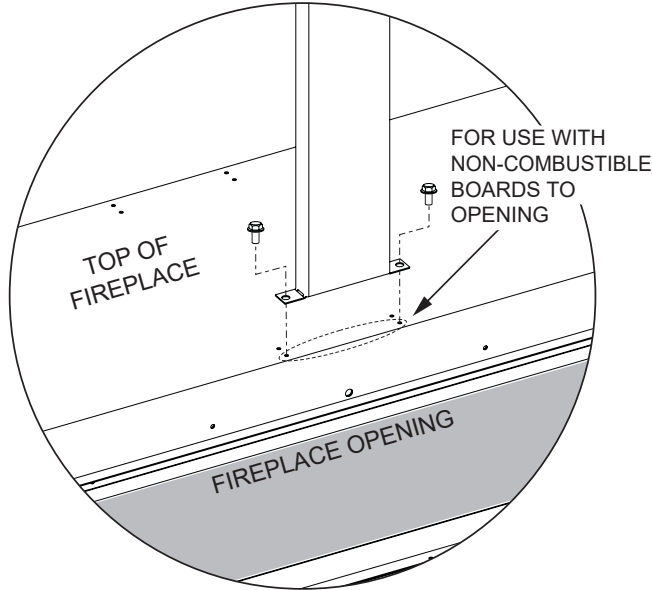


Figure 17 - OPTION 1

9b. **OPTION 2** - Secure the brackets to the fireplace top with screws. There are holes located in the top of the fireplace for each standoff bracket. The holes back further from the front edge of the fireplace are for mounting non-combustible board to the top of the fireplace so that tile or stone can cover the face. **Finishing OPTION 2. See Figure 18.**

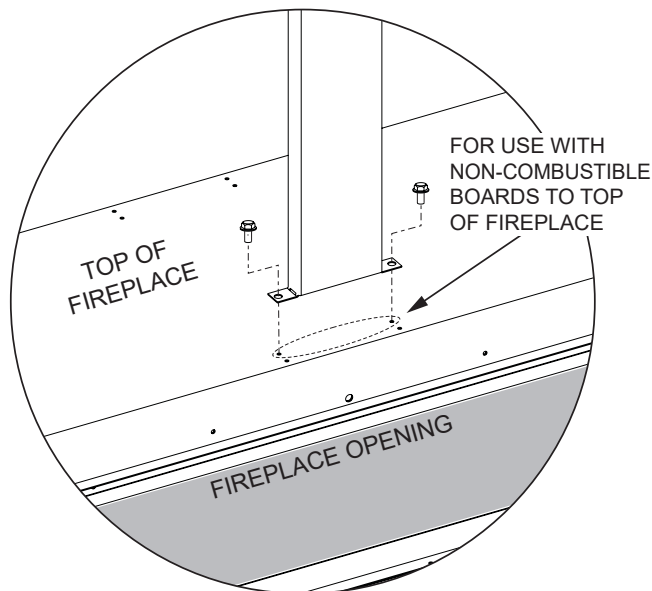


Figure 18 - OPTION 2

10a. **OPTION 1** - Secure standoff brackets with drywall screws to the framed opening above the fireplace as shown in **Figure 19.**

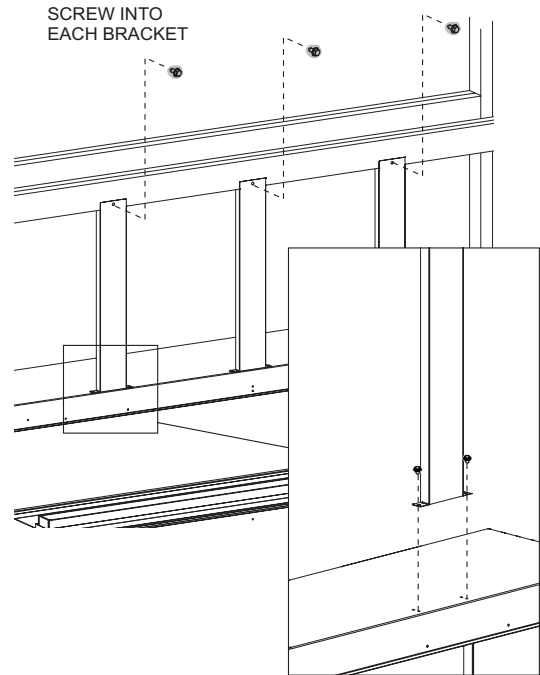


Figure 19 - OPTION 1

10b. **OPTION 2** - Secure standoff brackets with drywall screws to the framed opening above the fireplace as shown in **Figure 20.**

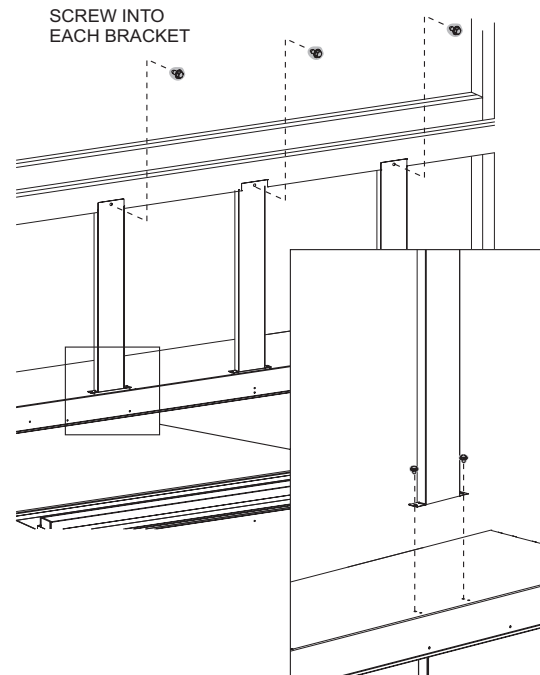


Figure 20 - OPTION 2

# UTILITY INSTALLATION - VFLB(36,48)

Remove barrier screen assembly from fireplace by lifting up slightly and pulling out. Set aside. Remove the burner cover by lifting it up and out. Set aside.

Bring the gas supply through the left or right side of the fireplace to connect to the burner. **See Figures 21 and 22.** Consult the current National Fuel Gas Code, ANSI Z223.1 CAN/CGA-B149 (.1 or .2) installation code.

## ⚠ CAUTION

**Never use plastic pipe. Check to confirm whether the local codes allow copper or galvanized tubing.**

**NOTICE:** Since some municipalities have additional local codes, it is always best to consult the local authority and installation code.

The use of the following gas connectors is recommended:

- ANSI Z21.24 Fireplace Connectors of Corrugated Metal Tubing and Fittings.
- ANSI Z21.45 Assembled Flexible Fireplace Connectors of Other Than All-Metal Construction

The connectors specified by the National Fuel Gas Code may be used if acceptable by the authority having jurisdiction. The Commonwealth of Massachusetts requires that a flexible fireplace connector cannot exceed three feet in length.

### FLEXIBLE GAS LINE CONNECTION

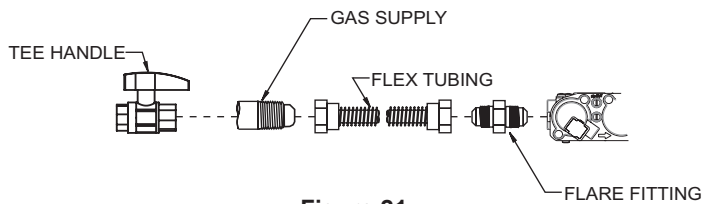


Figure 21

### INSTALLING THE MAIN GAS SHUT-OFF VALVE

Each fireplace should have its own manual gas shut-off valve (included). Locate the manual main gas shut-off valve in the vicinity of the fireplace easily accessible after assembly. Contact the local authorized installer for installation or relocation when no shut-off exists or the location is not adequate.

Compounds used on threaded joints of gas piping are resistant to the action of liquefied petroleum gases. Gas lines must be checked for leaks by the installer. A leak testing solution or soap should be used for testing leaks on all exposed connections.

After testing is complete, all solutions should be cleaned off. On unexposed connections, a pressure test should be made.

Never use an exposed flame to check for leaks. Fireplace must be disconnected from piping at inlet of control valve and pipe capped or plugged for pressure test. Never pressure test with fireplace connected; control valve will sustain damage.

When using copper or flex connector use only approved fittings. The fireplace and its individual shut-off valve must be disconnected from supply piping system during any pressure testing of that system at test pressures in excess of 1/2 psig (3.5kPa). The fireplace must be isolated from the gas supply piping system by closing its individual manual shut-off valve during any pressure testing of the gas supply piping system at test pressures equal to or less than 1/2 psig (3.5kPa).

### TESTING GAS SUPPLY PRESSURE

**NOTICE:** The gas controls are equipped with a captured screw-type pressure test point. It is not necessary to provide a 1/8-inch test point up stream of the control. Bleed gas line before testing gas pressure. Check for leaks.

### INTERMITTENT PILOT VALVES (VFLB(36,48)FP90)

Natural Gas will have a manifold pressure of approximately 3.5 inches w.c. at the pressure regulator outlet with the inlet pressure to the pressure regulator from a minimum of 7.0 inches w.c. for the purpose of input adjustment to a maximum of 10.5 inches w.c.

Propane Gas will have a manifold pressure approximately 10.0 inches w.c. at the pressure regulator outlet with the inlet pressure to the pressure regulator from a minimum of 11.0 inches w.c. for the purpose of input adjustment to a maximum of 13.0 inches w.c.

### MILLIVOLT VALVES (VFLB(36,48)FP30)

Natural Gas will have a manifold pressure of approximately 3.5 inches w.c. for maximum input or 1.6 inches w.c. for minimum input at the pressure regulator outlet with the inlet pressure to the pressure regulator from a minimum of 4.5 inches w.c. for the purpose of input adjustment to a maximum of 10.5 inches w.c.

Propane Gas will have a manifold pressure approximately 10.0 inches w.c. for maximum input or 6.3 inches w.c. for minimum input at the pressure regulator outlet with the inlet pressure to the pressure regulator from a minimum of 11.0 inches w.c. for the purpose of input adjustment to a maximum of 10.0 inches w.c.

A test gage connection is located on the gas valve for measuring gas pressure. The connections are two contained screws inside tapered hose slip connections.

GAS PRESSURE (Inches Water Column)			
Gas Type	Maximum	Minimum	Manifold
Natural	10.5	7.0	3.5
Propane	13.0	11.0	10.0

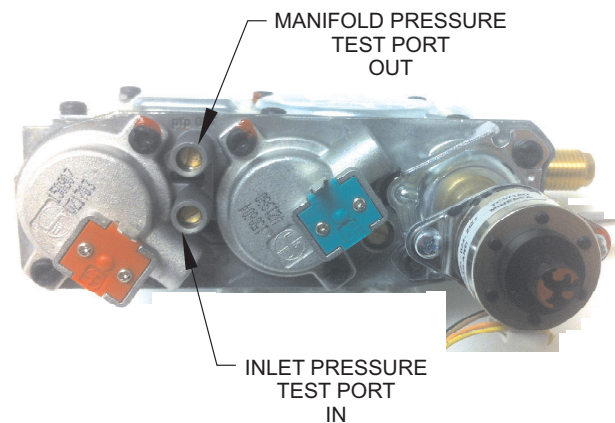


Figure 22

## ⚠ WARNING

**If one of the procedures results in pressures in excess of 1/2 psig (14 inches w.c.) (3.5 kPa) on the fireplace gas valve, it will result in a hazardous condition.**

# UTILITY INSTALLATION - VFLB(60,72)

Remove barrier screen assembly from fireplace by lifting up slightly and pulling out. Set aside. Remove the burner cover by lifting it up and out. Set aside.

Bring the gas supply through the left or right side of the fireplace to connect to the burner. **See Figures 23 and 24.** Consult the current National Fuel Gas Code, ANSI Z223.1 CAN/CGA-B149 (.1 or .2) installation code.

## ⚠ CAUTION

**Never use plastic pipe. Check to confirm whether the local codes allow copper or galvanized tubing.**

**NOTICE:** Since some municipalities have additional local codes, it is always best to consult the local authority and installation code.

The use of the following gas connectors is recommended:

- ANSI Z21.24 Fireplace Connectors of Corrugated Metal Tubing and Fittings.
- ANSI Z21.45 Assembled Flexible Fireplace Connectors of Other Than All-Metal Construction

The connectors specified by the National Fuel Gas Code may be used if acceptable by the authority having jurisdiction. The Commonwealth of Massachusetts requires that a flexible fireplace connector cannot exceed three feet in length.

### FLEXIBLE GAS LINE CONNECTION

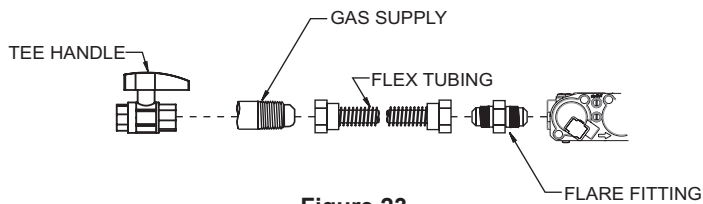


Figure 23

### INSTALLING THE MAIN GAS SHUT-OFF VALVE

Each fireplace should have its own manual gas shut-off valve. Locate the manual main gas shut-off valve in the vicinity of the fireplace easily accessible after assembly. Contact the local authorized installer for installation or relocation when no shut-off exists or the location is not adequate.

Compounds used on threaded joints of gas piping are resistant to the action of liquefied petroleum gases. Gas lines must be checked for leaks by the installer. A leak testing solution or soap should be used for testing leaks on all exposed connections.

After testing is complete, all solutions should be cleaned off. On unexposed connections, a pressure test should be made.

Never use an exposed flame to check for leaks. Fireplace must be disconnected from piping at inlet of control valve and pipe capped or plugged for pressure test. Never pressure test with fireplace connected; control valve will sustain damage.

When using copper or flex connector use only approved fittings. The fireplace and its individual shut-off valve must be disconnected from supply piping system during any pressure testing of that system at test pressures in excess of 1/2 psig (3.5kPa). The fireplace must be isolated from the gas supply piping system by closing its individual manual shut-off valve during any pressure testing of the gas supply piping system at test pressures equal to or less than 1/2 psig (3.5kPa).

### TESTING GAS SUPPLY PRESSURE

**NOTICE:** The gas controls are equipped with a captured screw-type pressure test point. It is not necessary to provide a 1/8-inch test point up stream of the control. Bleed gas line before testing gas pressure. Check for leaks.

Natural Gas will have a manifold pressure of approximately 3.5 inches w.c. at the pressure regulator outlet with the inlet pressure to the pressure regulator from a minimum of 7.0 inches w.c. for the purpose of input adjustment to a maximum of 10.5 inches w.c.

Propane Gas will have a manifold pressure approximately 10.0 inches w.c. at the pressure regulator outlet with the inlet pressure to the pressure regulator from a minimum of 11.0 inches w.c. for the purpose of input adjustment to a maximum of 13.0 inches w.c.

A test gage connection is located on the gas valve for measuring gas pressure. The connections are two contained screws inside the tapered hose slip connections.

GAS PRESSURE (Inches Water Column)			
Gas Type	Maximum	Minimum	Manifold
Natural	10.5	7.0	3.5
Propane	13.0	11.0	10.0

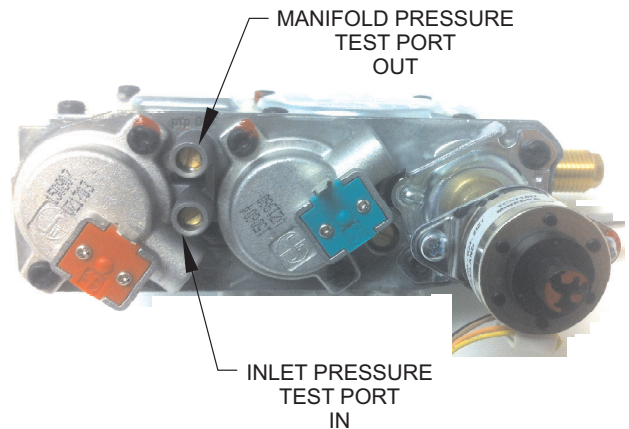
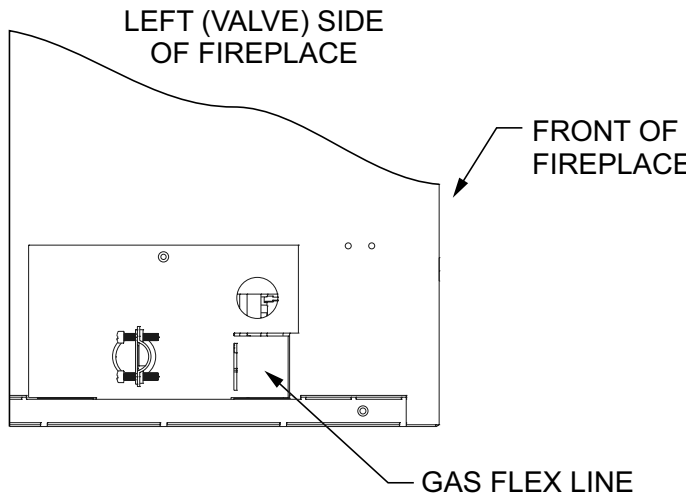


Figure 24

## ⚠ WARNING

**If one of the procedures results in pressures in excess of 1/2 psig (14 inches w.c.) (3.5 kPa) on the fireplace gas valve, it will result in a hazardous condition.**

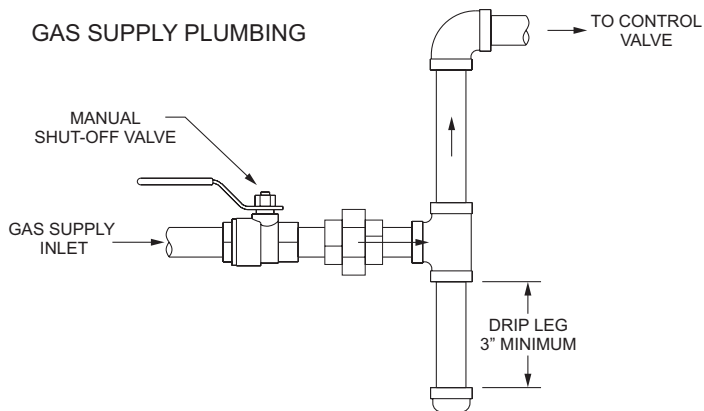
# UTILITY INSTALLATION (CONT'D)



**Figure 25**

Shut-off valve must be accessible after installation.

A gas valve and ground joint union should be installed in the gas line upstream of the gas control to aid in servicing. The National Fuel Gas Code requires that a drip leg be installed near the gas inlet. **See Figure 26.** This should consist of a vertical length of pipe tee connected into the gas line that is capped on the bottom in which condensation and foreign particles may collect.



**Figure 26**

Empire recommends using a flange and key shut-off valve.

# UTILITY INSTALLATION - VFLB(60,72) SHOWN (CONT'D)

## JUNCTION BOX WIRING INSTALLATION

A factory-installed junction box is located at the lower left corner inside the firebox. For 120V electrical requirements install the electrical receptacles into the junction box.

1. Remove the reflective burner cover by lifting straight up and then forward.
2. Remove burner box from fireplace. **See Figures 27 and 28.**

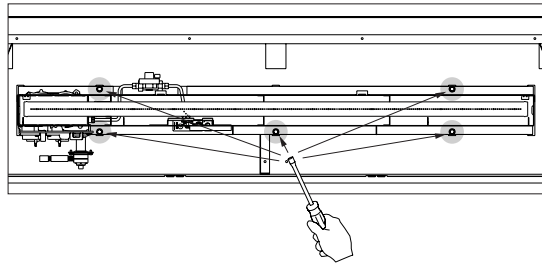


Figure 27

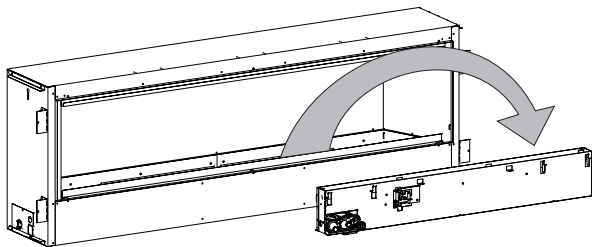


Figure 28

All wiring must be done by a qualified electrician and shall be in compliance with all local, city and state building codes. Before making the electrical connection, make sure the main power supply is disconnected. The fireplace, when installed, must be electrically grounded in accordance with local codes or, in the absence of local codes, with the National Electrical Code ANSI/NFPA 70 (latest edition).

### JUNCTION BOX CONNECTIONS

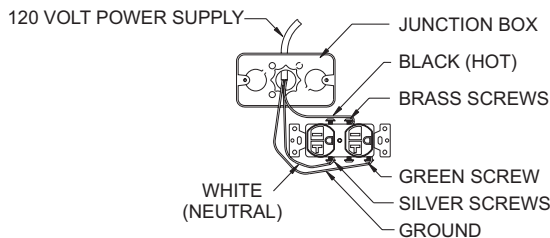


Figure 29

3. Remove the electrical access cover panel from the left end of the fireplace. **See Figure 29.**

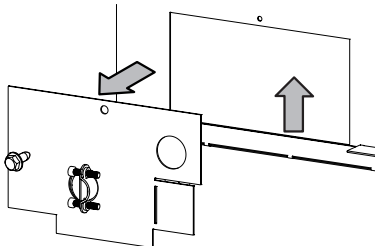


Figure 30

4. Run 14/2 Nm-B with ground or 12/2 Nm-B with ground wire through the electrical access panel into the Junction box. Attach the black wire to the receptacle, and the white wires to the receptacle as shown in **Figure 29**. Secure the incoming ground wire and green receptacle ground wires under the green ground screw provided in the junction box.
5. Attach receptacle to junction box with screws provided. **See Figure 31.**

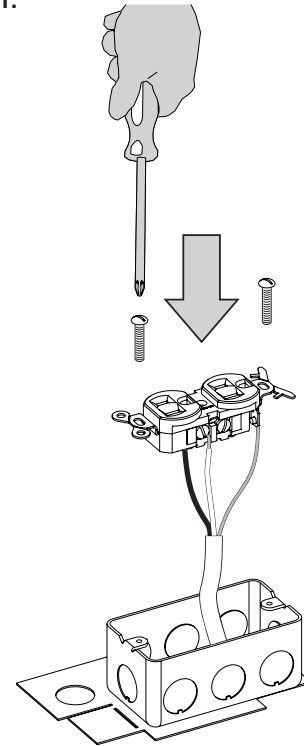


Figure 31

6. Re-install the junction box into the firebox using the screw removed in step 3. **See Figure 30.**
7. Install the Junction box cover. **See Figure 32.**

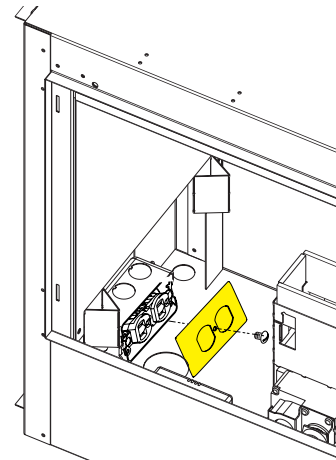


Figure 32

8. Connect flex line in burner box to inlet gas line.
9. Re-install burner box with screws removed earlier.
10. Check gas lines for leaks.
11. Plug AC adapter and LED transformer into junction box.

# UTILITY INSTALLATION - VFLB(60,72) SHOWN (CONT'D)

12. Install the wall-mounted control box within 6 feet to the left side or 4 feet from the right. See Figure 33.

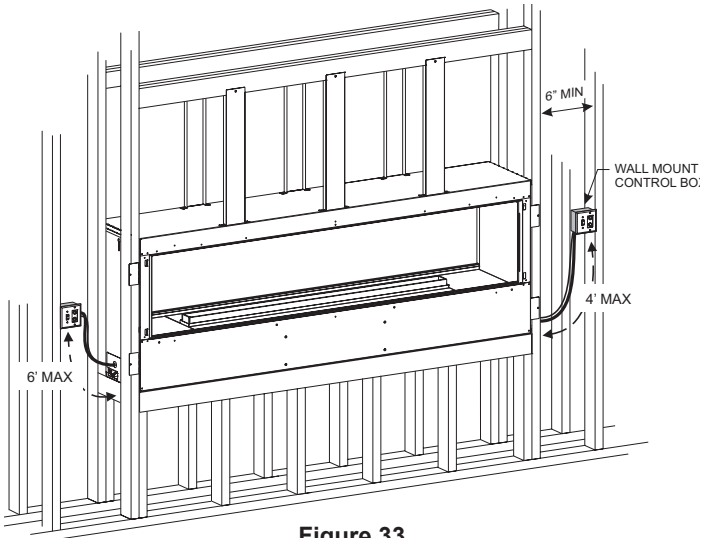


Figure 33

13. Install the provided plastic bushing in the opening where the wires exit the fireplace. See Figure 34 (left side), or Figure 35 (right side).

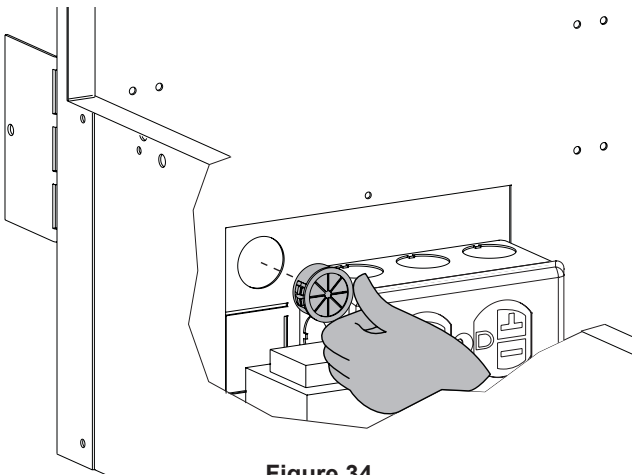


Figure 34

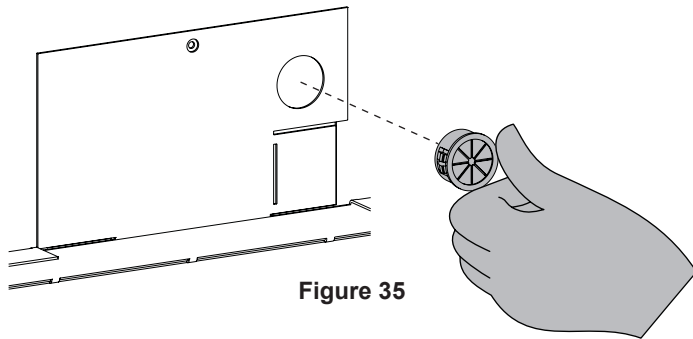


Figure 35

14. Route the yellow LED wire harness with gray remote receiver harness through the bushing. Mount the controls and connect the wiring. Secure wiring with provided zip tie as shown. See Figure 36.

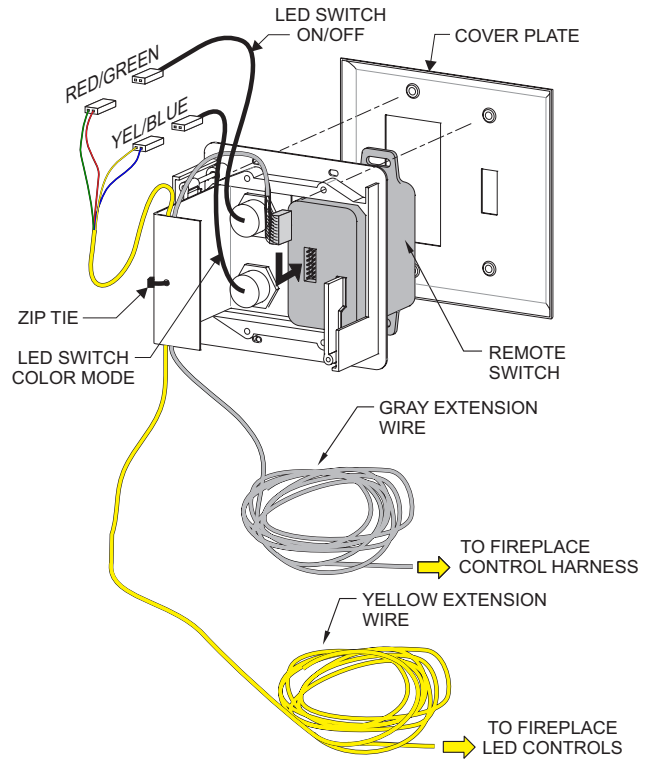


Figure 36

15. Place batteries in remote receiver and in the remote control using instructions provided. Place the switch slider to the remote switch.
16. Set the remote switch in wall box to remote. (center position) See Figure 37.

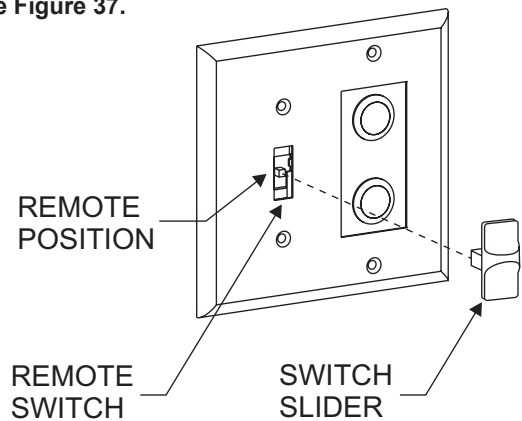


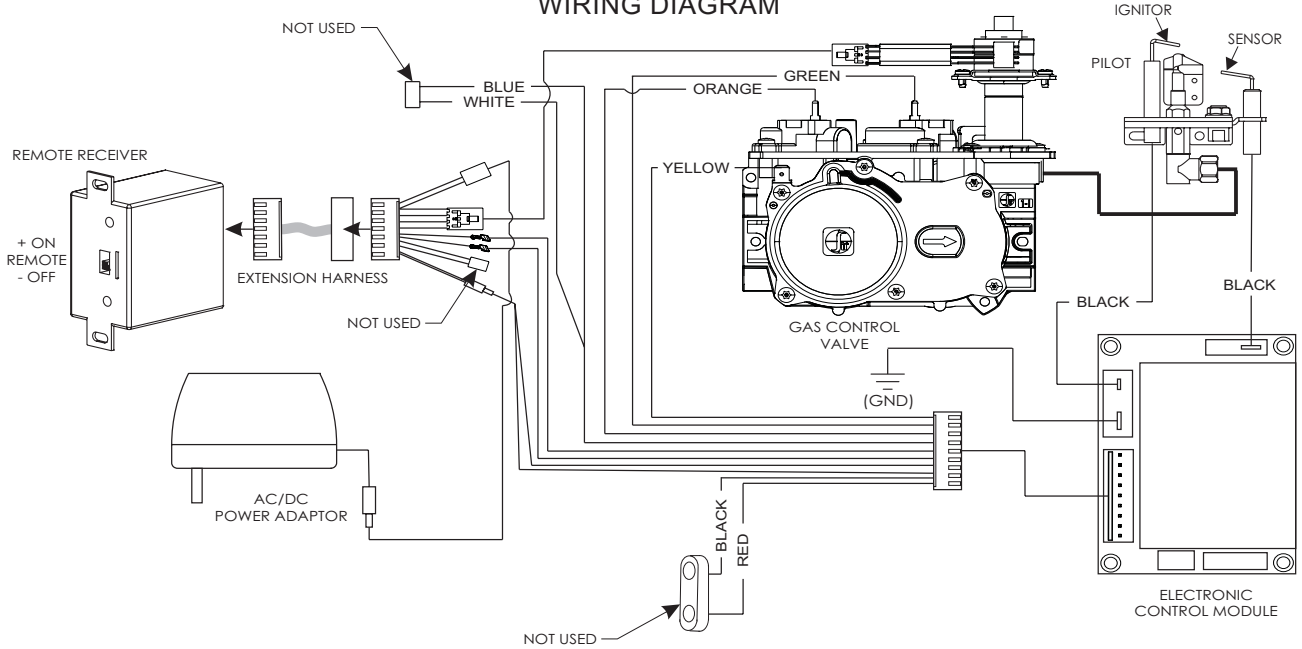
Figure 37

17. Verify remote is communicating with receiver. See Proflame control system page 41.
18. Test LEDs.
19. Test burner for ignition. See lighting instructions on pages 38 and 39.

ATTENTION: Test all components prior to sealing and finishing unit in the wall.

# UTILITY INSTALLATION - VFLB(60,72) SHOWN (CONT'D)

## WIRING DIAGRAM



Replace any damaged wiring with original wiring supplied by Empire Comfort Systems.

### CAUTION

Label all wires prior to disconnection when servicing controls. Wiring errors can cause improper and dangerous operation.

Verify proper operation after servicing.

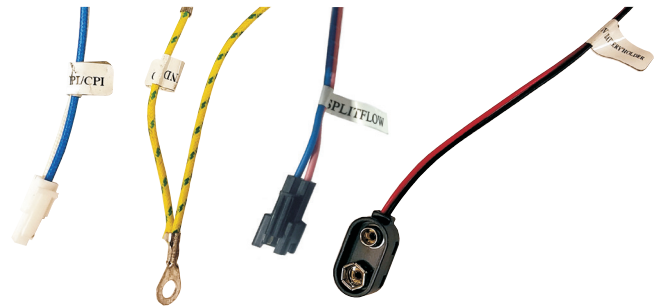


Figure 38

The wire terminals shown above in Figure 38 are not connected.

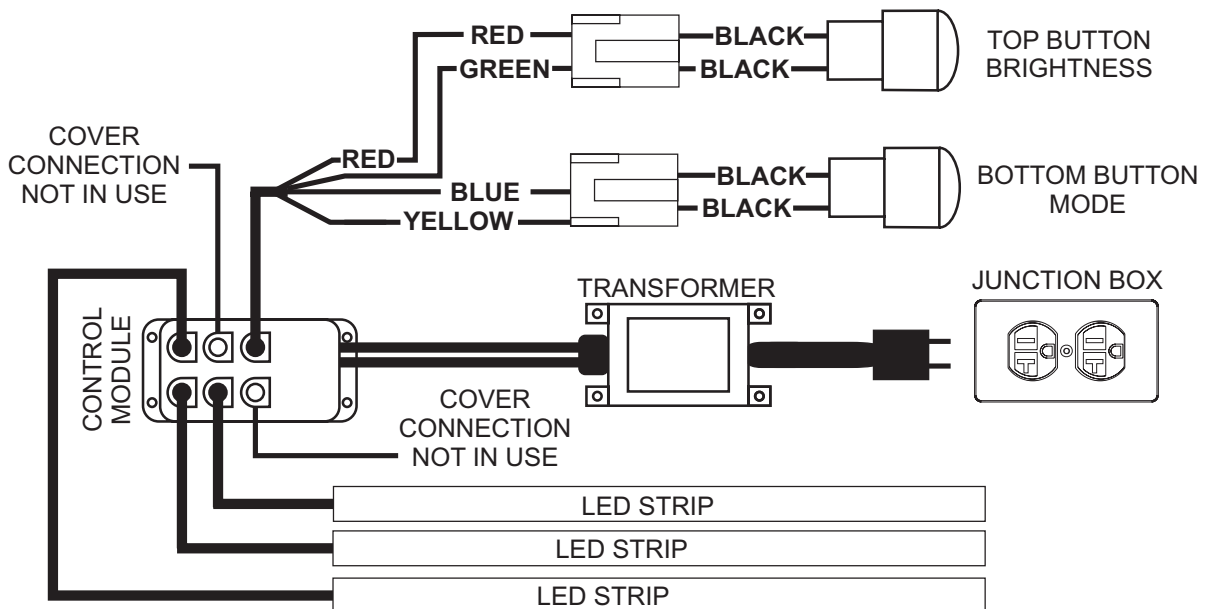


Figure 39

# INSTALLATION OPTION 1 - CLEAN FACE

**NOTICE:**

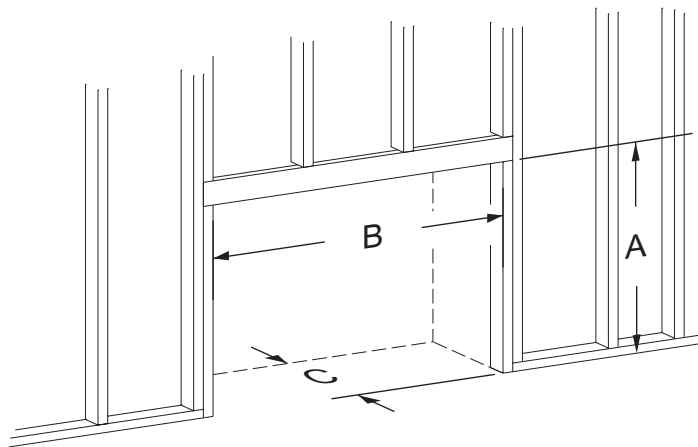
The steps on pages 29, 30 and 31 are for installation OPTION 1 - Clean Face.

This type of installation will allow for finishing around the fireplace face with high-temperature paint.

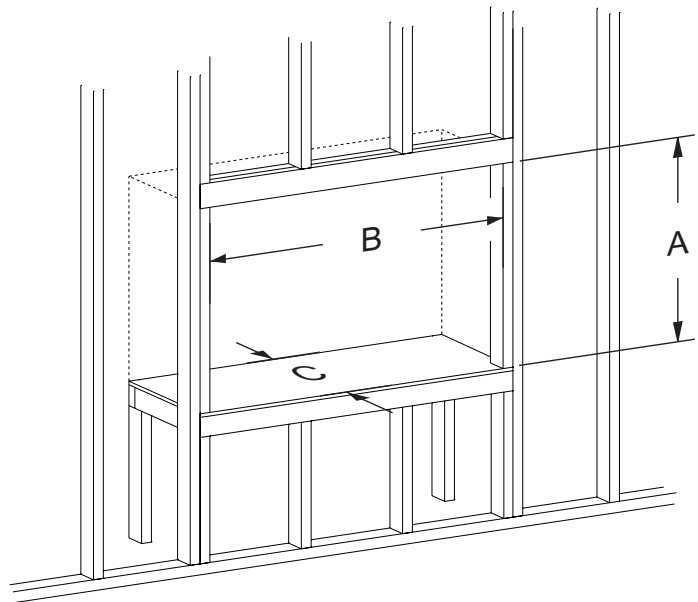
See pages 33, 34 and 35 for installing the fireplace for installation OPTION 2 - Flush Mount.

# OPTION 1 - CLEAN FACE (NON-COMBUSTIBLE BOARD INSTALLATION)

1. Frame in rough opening.
  - This fireplace is designed to be mounted on a hard, flat surface or raised platform.
  - Use dimensions shown in **Figure 40** for a conventional rough opening.
  - Use **Figure 41** for an elevated installation. Provide support to the bottom of the fireplace.
  - Use dimensions shown in **Figure 42** for corner rough opening. Be sure to provide gas line and electrical power for fireplace assembly.
2. Refer to Junction Box Wiring section on page 27 for details on electrical requirements.
3. Verify gas and electrical lines are ready for fireplace installation. See Gas Supply pages 22 and 23.



**Figure 40** - Rough Opening for Installing in Wall

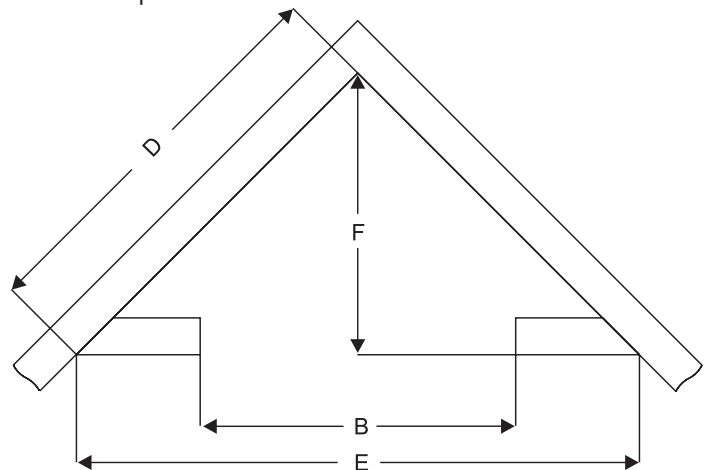


**Figure 41** - Rough Opening for Elevated Installation

TABLE 3 - FRAMING DIMENSIONS (In Inches) For Figures 40 - 42						
Model	A	B	C	D	E	F
VFLB36FP90	41-5/8	42-1/2	11-1/2	45-1/8	63-3/4	31-7/8
VFLB48FP90	41-5/8	54-1/2	11-1/2	53 5/8	75-3/4	37-7/8

TABLE 3 - FRAMING DIMENSIONS (In Inches) For Figures 40 - 42						
Model	A	B	C	D	E	F
VFLB60FP90	41-5/8	66-1/2	11-1/2	62	87-3/4	43-7/8
VFLB72FP90	41-5/8	78-1/2	11-1/2	70-1/2	99-3/4	49-7/8

\* Minimum clearance with 1/2-inch non-combustible board over face of fireplace.

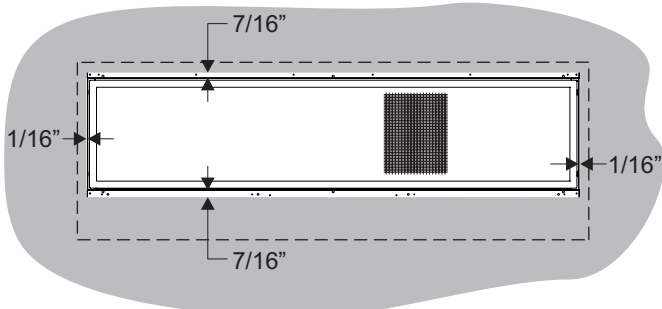


**Figure 42** - Rough Opening for Installing in Corner

# OPTION 1 - CLEAN FACE (NON-COMBUSTIBLE BOARD INSTALLATION)

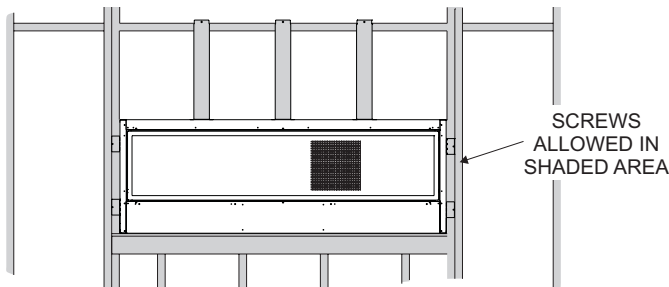
**NOTICE:** If installing a decorative front, an offset between the finishing materials and fireplace opening is required. Refer to the installation instructions provided with the decorative front before framing the opening.

- For installation of the **DF361VBL-1, DF362VBL-1, DF481VBL-1, DF482VBL-1, DF601VBL-1, DF602VBL-1, DF721VBL-1,** and **DF722VBL-1 kits**, 1/16-inch unfinished space is required to either side of the fireplace opening, and 7/16 inch unfinished space is required on top and bottom of the fireplace opening.



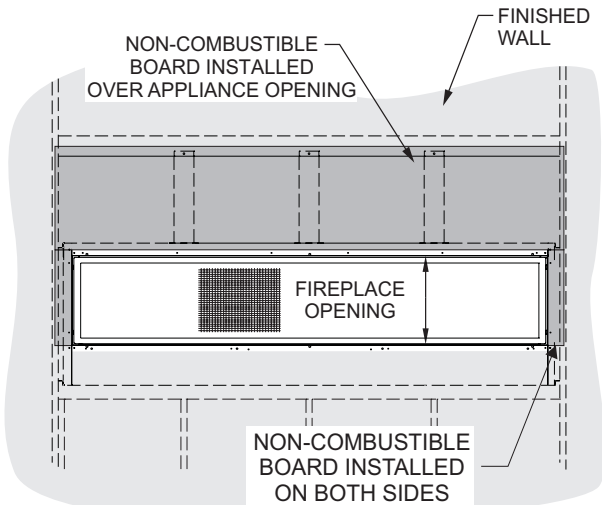
**Figure 43**

- Screws are allowed in framing and top mounting brackets. No screws are allowed into the fireplace. **See Figure 44.**

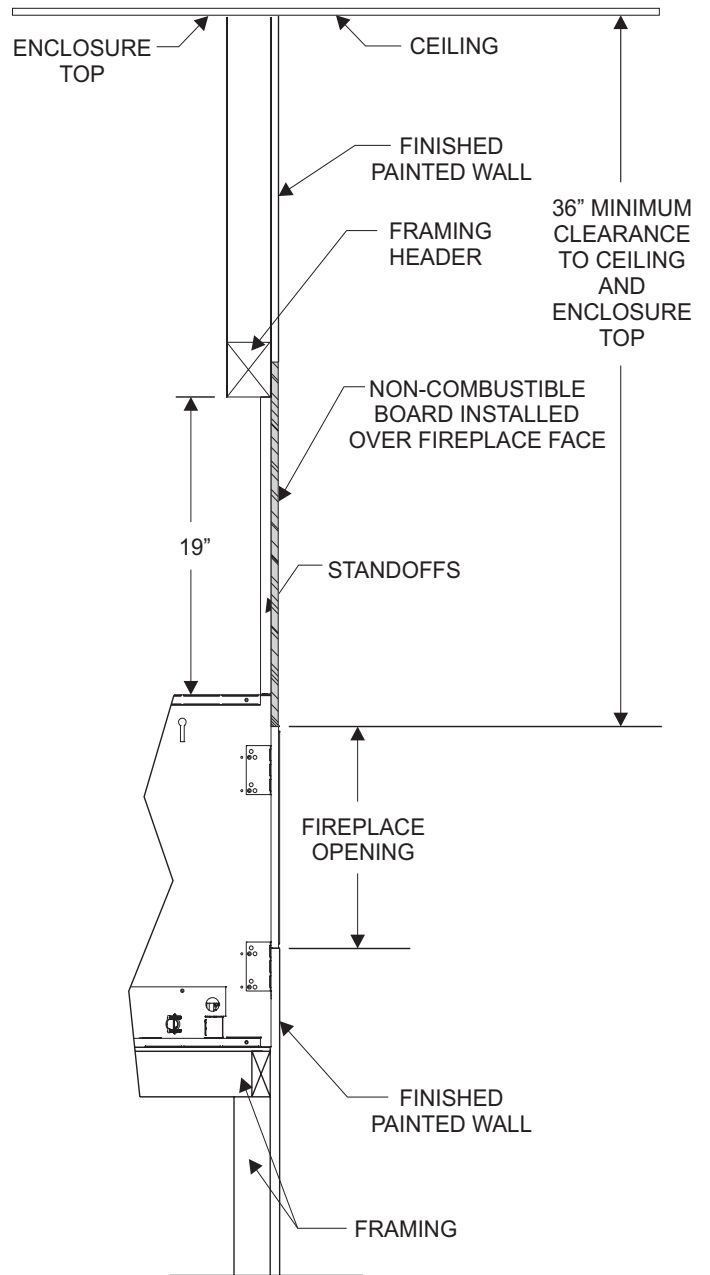


**Figure 44**

- Place upper non-combustible board above fireplace opening to required gap, and secure with screws in approved area,
- Place side non-combustible boards to the side of each opening to required gap and secure with screws in approved area.



**Figure 45**



**Figure 46**

**NOTICE:** Standoffs and non-combustible board shown for reference.

## OPTION 1 - CLEAN FACE (NON-COMBUSTIBLE BOARD INSTALLATION)

4. Install non-combustible board provided with the fireplace.  
**See Figure 45.**
  - Do not attach non-combustible board to the fireplace. Attach non-combustible board only to framing and standoffs.
  - Space non-combustible board 1/16 inch off of fireplace opening flanges to allow for expansion during operation.
  - Predrill holes into non-combustible board and counter-sink.
  - For best results treat non-combustible board and area around the board with Kilz primer prior to applying adhesive or sealing compound.
  - Apply adhesive in joints between non-combustible board panels.
  - Use only high-temperature adhesive and high-temperature paints rated for minimum 300° F with the non-combustible board.
5. Finish Wall.
  - Use woven fiberglass joint tape and Durabond 45 joint compound for best results when finishing non-combustible panel and drywall joints around fireplace.
  - Tile or non-combustible materials can be applied on top of the non-combustible board and finished wall as their instructions require.

### NOTICE FOR FINISHING MATERIALS

The wall above the fireplace will become hot. Install the non-combustible board supplied with the fireplace before adding paint, tile or stone. Attach tile or other non-combustible products to the fireplace face and to the non-combustible area using adhesives designed for high-temperature applications. Follow the manufacturer's instructions for application and curing times. Heat from the fireplace may cause incorrectly installed materials to fail. If you are painting above the fireplace, use a coating designed for high temperature environments and follow the manufacturer's instructions for surface preparation, application and curing. Heat from the fireplace may cause incorrectly applied coatings to fail or discolor.

Due to the variable properties of natural stone, the material may have stress points that are unpredictable when installed above or around the fireplace. These stress points may result in cracking of the finish materials. Empire Comfort Systems is not responsible for the finishing materials used with our fireplaces.

### CAUTION

**Failure to use a 300°F minimum adhesive may allow the finishing material to fall.**

## INSTALLATION OPTION 2 - FLUSH MOUNT

**NOTICE:**

The steps on pages 33, 34, and 35 are for installation OPTION 2 - Flush Mount.

This type of installation will allow for applying tile, marble, stone or other non-combustible materials over the face of the fireplace cabinet up to the flange opening.

See pages 29, 30 and 31 for installation OPTION 1 - Clean Face.

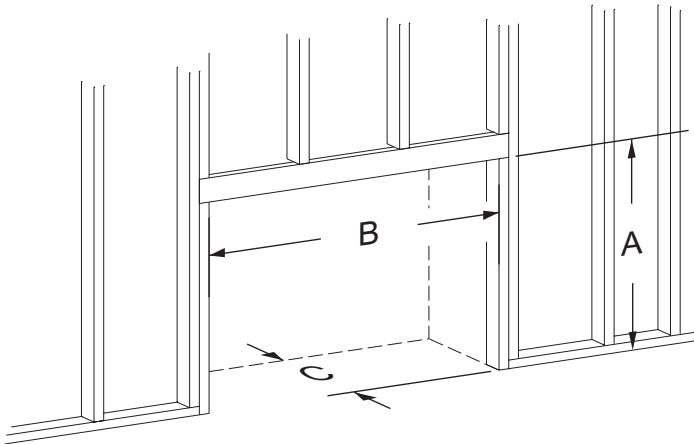
# OPTION 2 - FLUSH FACE (NON-COMBUSTIBLE BOARD INSTALLATION)

1. Frame in rough opening.
  - This fireplace is designed to be mounted on a hard, flat surface or raised platform.
  - Use dimensions shown in **Figure 47** for a conventional rough opening.
  - Use **Figure 48** for an elevated installation. Provide support to the bottom of the fireplace.
  - Use dimensions shown in **Figure 49** for corner rough opening. Be sure to provide gas line and electrical power for fireplace assembly.
2. Refer to Junction Box Wiring section on page 27 for details on electrical requirements.
3. Verify gas and electrical lines are ready for fireplace installation. See Gas Supply pages 22 and 23.

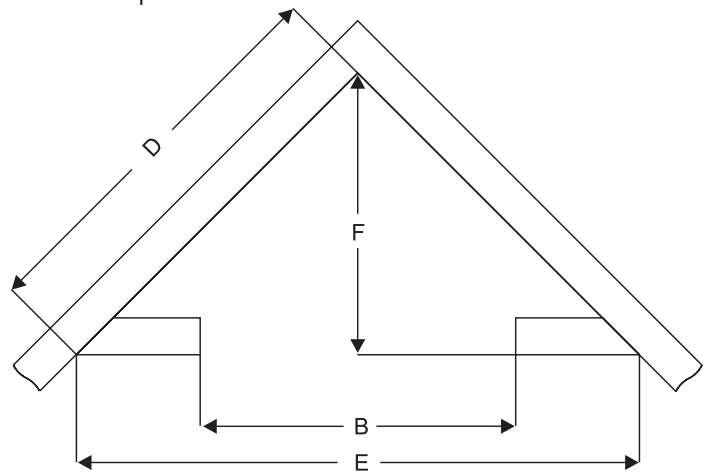
TABLE 4 - FRAMING DIMENSIONS (In Inches) For Figures 47 - 49						
Model	A	B	C	D	E	F
VFLB36FP90	41-5/8	42-1/2	11-1/2	45-5/8	64-1/2	32-1/4
VFLB48FP90	41-5/8	54-1/2	11-1/2	64	75-3/4	45-1/4

TABLE 4 - FRAMING DIMENSIONS (In Inches) For Figures 47 - 49						
Model	A	B	C	D	E	F
VFLB60FP90	41-5/8	66-1/2	11	62-5/8	88-1/2	44-1/4
VFLB72FP90	41-5/8	78-1/2	11	71-1/8	100-1/2	50-1/4

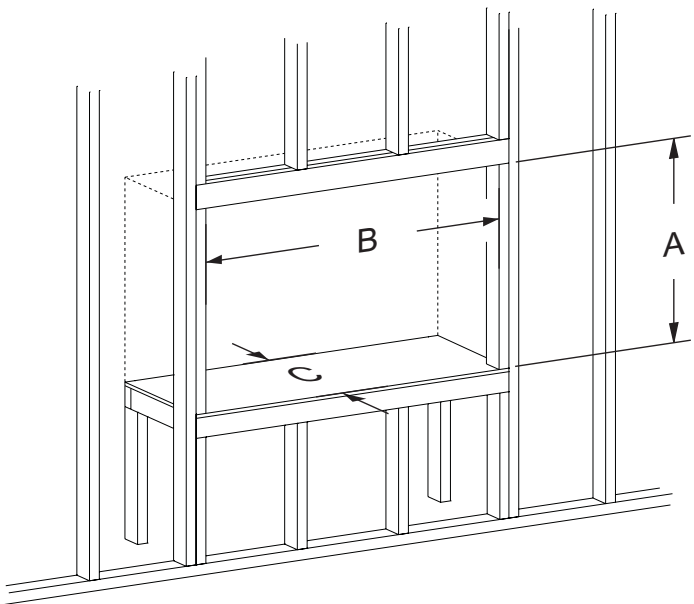
\* Minimum clearance with 1/2-inch non-combustible board over face of fireplace.



**Figure 47** - Rough Opening for Installing in Wall



**Figure 49** - Rough Opening for Installing in Corner

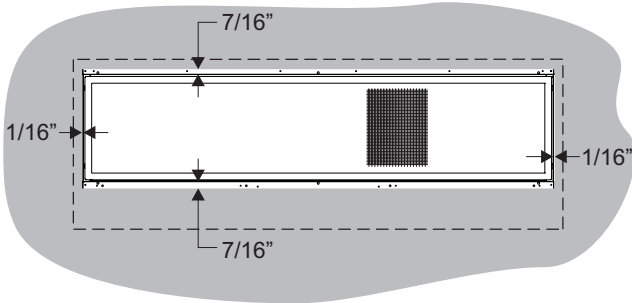


**Figure 48** - Rough Opening for Elevated Installation

# OPTION 2 - FLUSH FACE (NON-COMBUSTIBLE BOARD INSTALLATION)

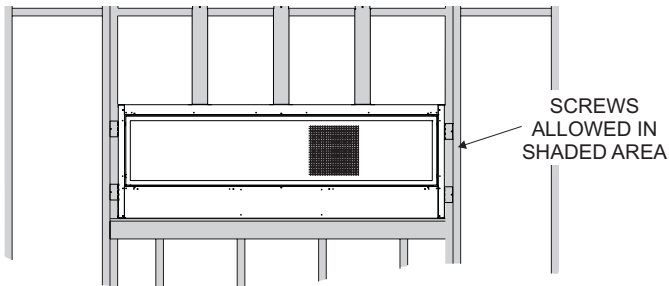
**NOTICE:** If installing a decorative front, an offset between the finishing materials and fireplace opening is required. Refer to the installation instructions provided with the decorative front before framing the opening.

- For installation of the **DF361VBL-1, DF362VBL-1, DF481VBL-1, DF482VBL-1, DF601VBL-1, DF602VBL-1, DF721VBL-1, and DF722VBL-1 kits**, 1/16-inch unfinished space is required to either side of the fireplace opening, and 7/16-inch unfinished space is required on top and bottom of the fireplace opening.



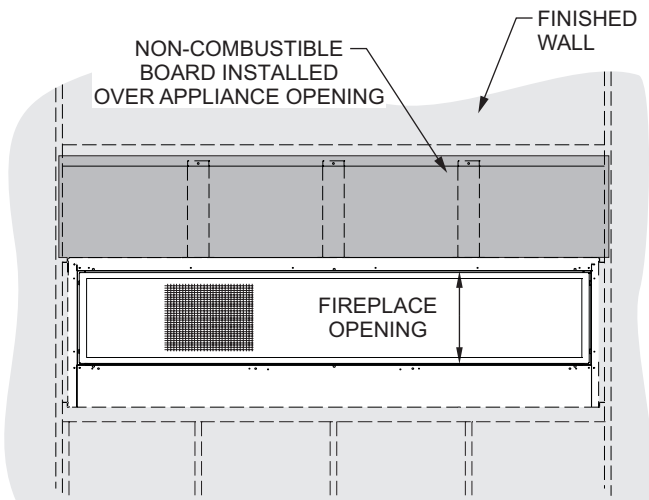
**Figure 50**

- Screws are allowed in framing and top mounting brackets. No screws are allowed into the fireplace face. **See Figure 51.**

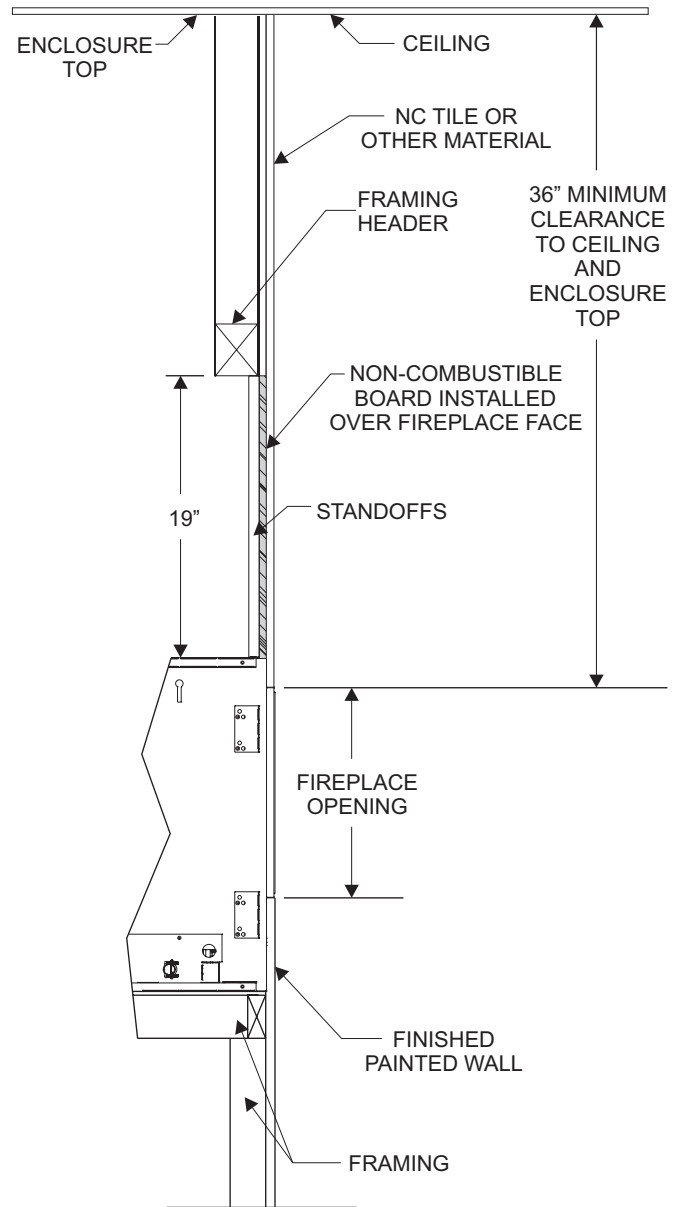


**Figure 51**

- Place the non-combustible board above fireplace opening to required height, and secure with screws in approved area,
- Side non-combustible boards not used in this application.



**Figure 52**



**Figure 53**

**NOTICE:** Standoffs and non-combustible board shown for reference.

## OPTION 2 - FLUSH FACE (NON-COMBUSTIBLE BOARD INSTALLATION)

4. Install non-combustible board provided with the fireplace.  
**See Figure 52.**
  - Do not attach non-combustible board to the fireplace face. Attach non-combustible board only to the framing and standoffs.
  - Space non-combustible board 1/16 inch off of fireplace opening flanges to allow for expansion during operation.
  - Predrill holes into non-combustible board and counter-sink.
  - For best results treat non-combustible board and area around the board with Kilz primer prior to applying adhesive or sealing compound.
  - Apply adhesive in joints between non-combustible board panels.
  - Use only high-temperature adhesive and high-temperature paints rated for minimum 300° F with the non-combustible board.
5. Finish Wall.
  - Use woven fiberglass joint tape and Durabond 45 joint compound for best results when finishing non-combustible panel and drywall joints around fireplace.
  - Tile or non-combustible materials can be applied on top of the non-combustible board and finished wall as their instructions require.

### NOTICE FOR FINISHING MATERIALS

The wall above the fireplace will become hot. Install the non-combustible board supplied with the fireplace before adding paint, tile or stone. Attach tile or other non-combustible products to the fireplace face and to the non-combustible area using adhesives designed for high-temperature applications. Follow the manufacturer's instructions for application and curing times. Heat from the fireplace may cause incorrectly installed materials to fail. If you are painting above the fireplace, use a coating designed for high temperature environments and follow the manufacturer's instructions for surface preparation, application and curing. Heat from the fireplace may cause incorrectly applied coatings to fail or discolor.

Due to the variable properties of natural stone, the material may have stress points that are unpredictable when installed above or around the fireplace. These stress points may result in cracking of the finish materials. Empire Comfort Systems is not responsible for the finishing materials used with our fireplaces.

### CAUTION

**Failure to use a 300°F minimum adhesive may allow the finishing material to fall.**

# COMPLETING INSTALLATION

## ⚠ WARNING

Failure to position the parts in accordance with the diagrams and instructions below or failure to use only parts specifically approved for use with this fireplace may result in property damage or personal injury.

**NOTICE:** During setup the burner may be operated with or without the optional Decorative accessories.

1. If installing an optional decorative front, install it at this time. Refer to the instructions provided with the decorative front kit.
2. If installing an optional liner, install it at this time. Refer to the instructions provided with the liner kit.
3. If installing an optional light kit, install it at this time. Refer to the instructions provided with the light kit.
4. Install the burner cover assembly as shown in **Figure 54**.

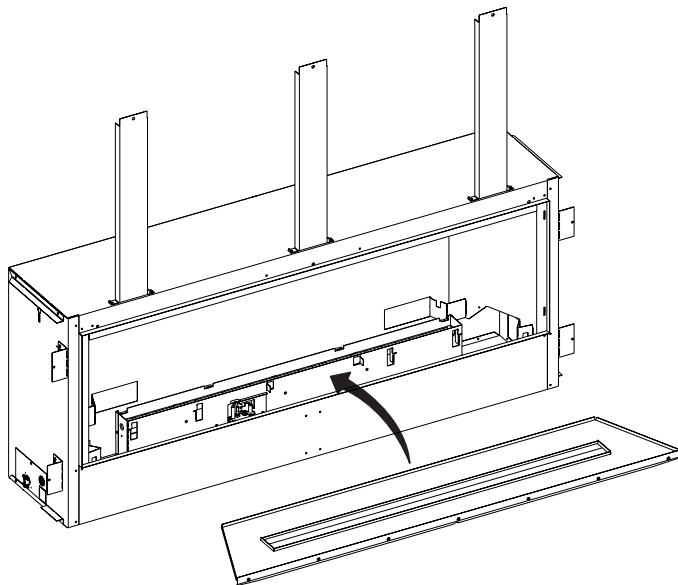


Figure 54

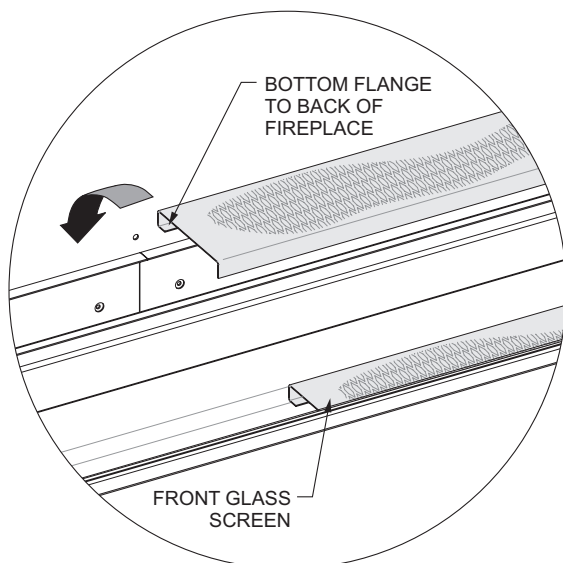


Figure 55

5. Retrieve the 3 glass panels and install on front and both sides of burner. See **Figure 56**.

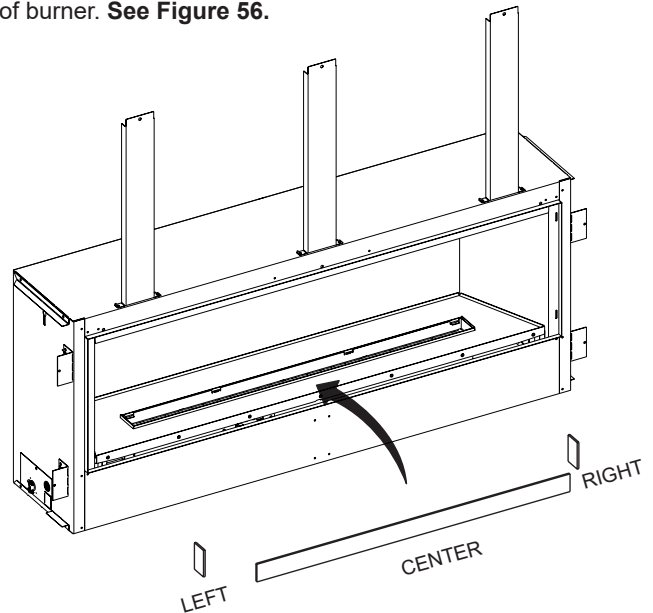


Figure 56

6. If installing the optional log/rock set, refer to the log set instruction manual for placing them around the burner.
7. If installing optional Decorative Glass, install it at this time.

**NOTICE:** VFLB36FP will accept 1.75 square feet of Decorative Glass and VFLB48FP will accept 2.25 square feet of Decorative Glass.

**NOTICE:** VFLB60FP will accept 5 square feet of Decorative Glass and VFLB72FP will accept 6 square feet of Decorative Glass.

## ⚠ WARNING

Crushed glass must not be more than a single layer. Do not use more glass than recommended. Using excess glass may cause injury or property damage.

## ⚠ WARNING

Use only decorative rocks and glass designed for use in a fireplace. Using other materials may cause a situation where injury or property damage may occur.

## ⚠ WARNING

Never place media materials on or next to the burner.

The Decorative Glass options are available in various colors and package sizes. Choose the size appropriate for the fireplace. See list on page 8.

## ⚠ CAUTION

To prevent injury, use gloves and eye protection while applying the decorative glass or droplets.

Application of the Decorative Glass or Rocks should only be performed after the burner has been fully installed, secured and tested for leaks.

# COMPLETING INSTALLATION (CONT'D)

8. Apply the accessory decorative glass or rocks to the shaded area only. **See Figure 57.** Use enough to cover the area of the fireplace, but do not allow the media to reach higher than the flange surrounding the burner. Never place decorative media inside the flange surrounding the burner itself. This fireplace can use crushed glass, glass droplets (1/2 inch) or glass drops (1 inch), or ceramic fiber rocks and pebbles. Mix colors and glass types, but do not exceed the recommended amount of decorative media.

**CAUTION**

Glass or rocks must not be placed around the ends or over the front edge of the burner assembly. Do not restrict air flow.

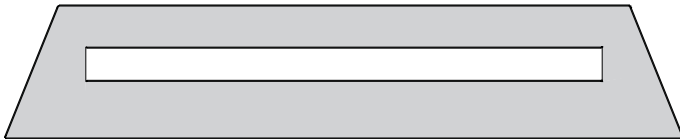


Figure 57

QUANTITY OF GLASS	
Model	Amount
VFLB36FP	1.75 square feet
VFLB48FP	2.25 square feet
VFLB60FP	5 square feet
VFLB72FP	6 square feet

9. Replace the Barrier Screen onto the fireplace by lining up the tabs with the slots in the firebox. Push the barrier screen toward the unit and lower it slightly to lock in place. **See Figures 58-59.**

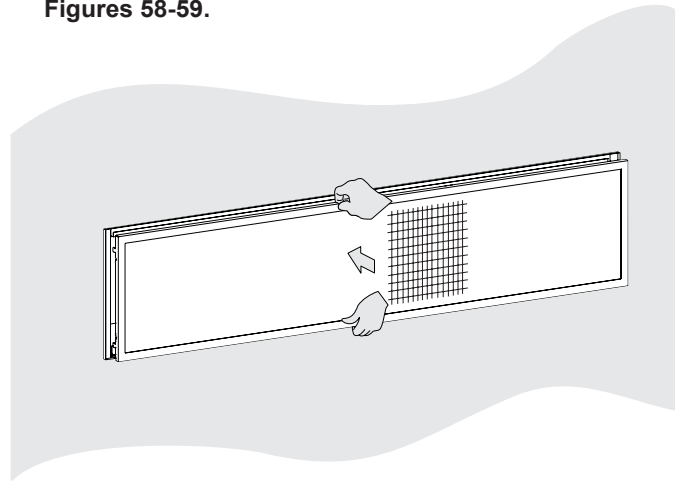


Figure 58

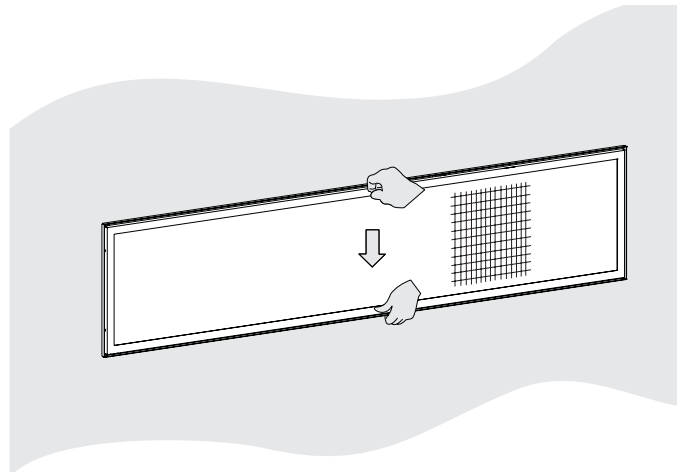


Figure 59

10. Test fireplace using remote and show owner how to use the remote. Show owner lighting instructions on page 35 for Intermittent Pilot or 36 for Millivolt models.
11. Installation of fireplace is complete. Leave this manual with owner.

# INTERMITTENT PILOT VALVE LIGHTING INSTRUCTIONS



## FOR YOUR SAFETY READ BEFORE LIGHTING

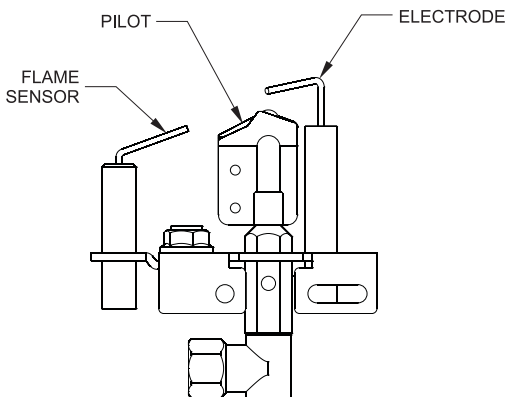
### ⚠ WARNING

If you do not follow these instructions exactly, a fire or explosion may result causing property damage, personal injury or loss of life.

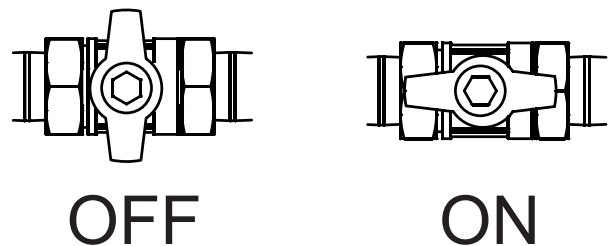
- A. This appliance has a pilot which can be lit by hand or by switching the remote receiver switch to the "ON" position. When lighting the pilot, follow these instructions exactly.
- B. **BEFORE LIGHTING** smell all around the appliance area for gas. Be sure to smell next to the floor because some gas is heavier than air and will settle on the floor.
- WHAT TO DO IF YOU SMELL GAS**
- Do not try to light any appliance.
  - Do not touch any electrical switch;
  - Do not use any phone in your building.
  - Immediately call your gas supplier from a neighbor's phone. Follow the gas supplier's instructions.
  - If you cannot reach your gas supplier, call the fire department.
- C. If applicable, use only your hand to turn the gas shut-off valve handle. Never use tools. If the handle will not turn by hand, don't try to repair it; call a qualified service technician. Force or attempted repair may result in a fire or explosion.
- D. Do not use this appliance if any part has been under water. Immediately call a qualified service technician to inspect the appliance and to replace any part of the control system and any gas control which has been under water.

## LIGHTING INSTRUCTIONS


1. **STOP!** Read the safety information above.
2. Turn OFF electric power to the appliance.
3. Turn gas shutoff valve counterclockwise  to On position.
4. Wait ten (10) minutes to clear out any gas. Then smell for gas, including near the floor. If you smell gas, **STOP!** Follow B in the safety information above on this page. If you do not smell gas, go to the next step.
5. Turn ON electric power to the appliance.
6. Find pilot. The pilot is next to the burner.
7. Turn main flame to on. If the pilot does not light within 60 seconds, stop and go to Step 5.
8. Refer to remote control instructions for detailed information, control features, and operation. **NOTICE:** There is a CPI/IPI switch for a continuous standing pilot mode or an intermittent pilot mode. See appliance manual for location of this switch. If the pilot or burner does not stay lit (in the standing pilot mode), stop and immediately call a qualified service technician or gas supplier.
9. If the burner or pilot does not operate properly after several tries, turn the gas valve clockwise  to OFF and call your service technician or gas supplier.
10. Operation of the gas valve is controlled by a manual on/off switch or a hand held remote control. Refer to remote instructions for detailed operation information.



### GAS SHUT-OFF VALVE



## TO TURN OFF GAS TO FIREPLACE

1. Set REMOTE/OFF/ON switch to OFF.
2. Turn off all electric power to the appliance if service is to be performed (if applicable).
3. Turn gas shut-off clockwise  to OFF. Do not force.

# MILLIVOLT CONTROL VALVE LIGHTING INSTRUCTIONS


## FOR YOUR SAFETY READ BEFORE LIGHTING

### ⚠ WARNING

If you do not follow these instructions exactly, a fire or explosion may result causing property damage, personal injury or loss of life.

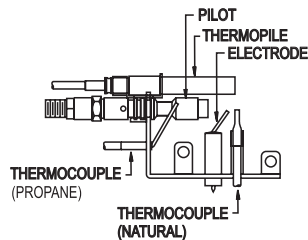
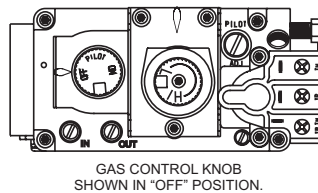
- A. This appliance has a pilot which must be lighted by hand. When lighting the pilot, follow these instructions exactly.
- B. **BEFORE LIGHTING** smell all around the appliance area for gas. Be sure to smell next to the floor because some gas is heavier than air and will settle on the floor.  
**WHAT TO DO IF YOU SMELL GAS:**
  - Do not try to light any appliance.
  - Do not touch any electrical switch; Do not use any phone in your building.
  - Immediately call your gas supplier from a neighbor's phone. Follow the gas supplier's instructions.
  - If you cannot reach your gas supplier, call the fire department.
- C. Use only your hand to push in or turn the gas control knob. Never use tools. If the knob will not push in or turn by hand, don't try to repair it; call a qualified service technician. Force or attempted repair may result in a fire or explosion.
- D. Do not use this appliance if any part has been under water. Immediately call a qualified service technician to inspect the appliance and to replace any part of the control system and any gas control which has been under water.



## LIGHTING INSTRUCTIONS

1. **STOP!** Read the safety information label.
2. Open bottom louver assembly (if applicable).
3. Set REMOTE/OFF/ON switch to "OFF."
4. Turn off all electric power to the appliance (if applicable).
5. Push in gas control knob slightly and turn clockwise  to "OFF."

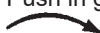
**NOTE:** Knob cannot be turned from "PILOT" to "OFF" unless knob is pushed in slightly. Do not force.

6. Wait ten (10) minutes to clear out any gas. Then smell for gas, including near the floor. If you smell gas, **STOP!** Follow "B" in the safety information above. If you do not smell gas, go to the next step.
7. Find pilot - Follow metal tube from gas control. The pilot is in front of the burner on the right side.



8. Turn gas control knob counterclockwise  to "PILOT."
9. Push in control knob all the way and hold in. Repeatedly push the Piezo Ignitor Button until the pilot is lit. Continue to hold the control knob in for about one (1) minute after the pilot is lit. Release knob, and it will pop back up. Pilot should remain lit. If it goes out, repeat steps 5 through 9.
  - If knob does not pop up when released, STOP and IMMEDIATELY call a qualified service technician or gas supplier.
  - If the pilot will not stay lit after several tries, turn the gas control knob to "OFF" and call your service technician or gas supplier.
10. Turn gas control knob counterclockwise  to "ON."
11. Set REMOTE/OFF/ON switch to desired setting.
12. Turn on all electric power to the appliance (if applicable).
13. Close bottom louver assembly (if applicable).

## TO TURN OFF GAS TO FIREPLACE

1. Open bottom louver assembly (if applicable).
2. Set REMOTE/OFF/ON switch to "OFF."
3. Turn off all electric power to the appliance if service is to be performed (if applicable).
4. Push in gas control knob slightly and turn clockwise  to "OFF." Do not force.
5. Close bottom louver assembly (if applicable).

# PILOT FLAME CHARACTERISTICS

Figures 60 and 62 shows a correct pilot flame pattern. The correct flame will be blue and will extend beyond the flame sensor or thermocouple. The flame will surround the flame sensor or thermocouple just below the tip. A slight yellow flame may occur where the pilot flame and main burner flame meet. Figures 61 and 63 shows an incorrect pilot flame pattern. The incorrect pilot flame is not touching the flame sensor or thermocouple. This will cause the flame sensor or thermocouple to cool. When the flame sensor or thermocouple cools, the fireplace will shut down.

Flames from the pilot (front center of burner) as well as the main flame should be visually checked as the fireplace is installed.

In normal operation at full rate after 10 to 15 minutes, the flame appearance should be sets of yellow flames.

**NOTICE:** All flames will be random by design, flame height will go up and down.

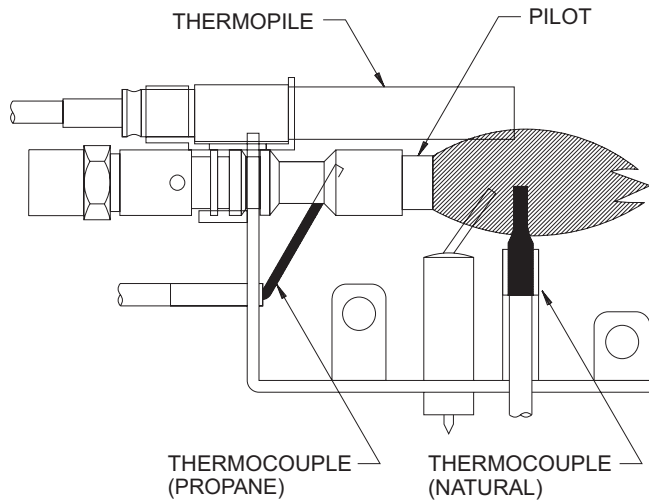


Figure 60 - Correct Pilot Flame Pattern for MILLIVOLT

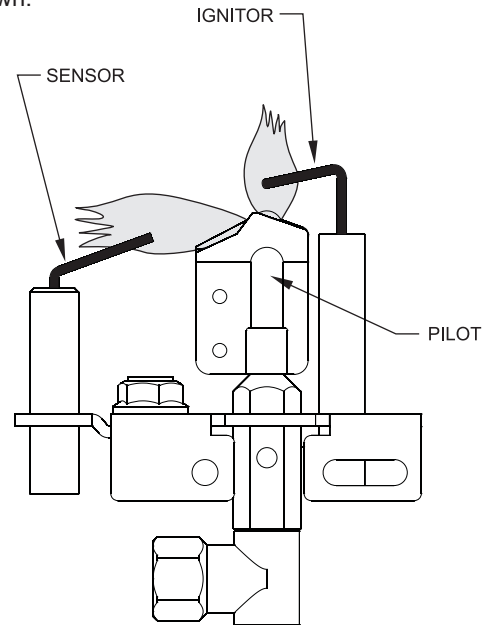


Figure 62 - Correct Pilot Flame Pattern for INTERMITTENT PILOT

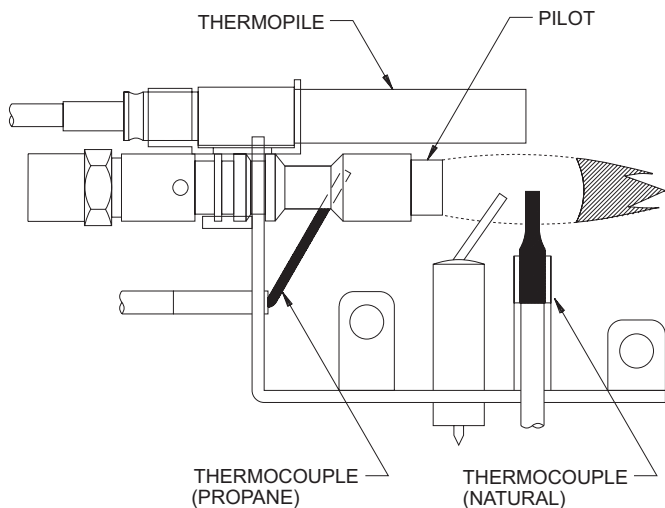


Figure 61 - Incorrect Pilot Flame Pattern for MILLIVOLT

If pilot flame pattern is incorrect, as shown in Figure 61: See Millivolt Troubleshooting, pages 54-55.

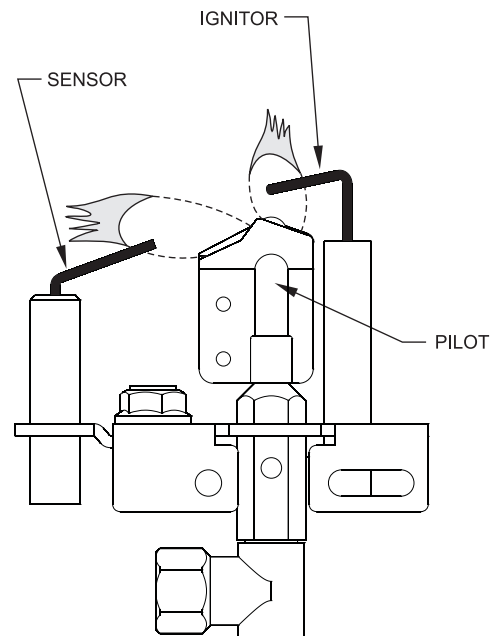


Figure 63 - Incorrect Pilot Flame Pattern for INTERMITTENT PILOT

If pilot flame pattern is incorrect, as shown in Figure 63:

- See Intermittent Pilot Troubleshooting, pages 51-53.

# PROFLAME - IP CONTROL SYSTEM

TECHNICAL DATA	
<b>Remote Control</b>	
Supply voltage	4.5 V (three 1.5 V AAA batteries)
Ambient temperature ratings	0-50°C (32 - 122°F)
Radio frequency	315 MHz
<b>RECEIVER</b>	
Supply voltage	6.0 V (four 1.5 V AA batteries)
Ambient temperature ratings	0-60°C (32 - 140°F)
Radio frequency	315MHZ

**⚠ WARNING**

The transmitter and receiver are radio frequency devices. Placing the receiver in or near metal may severely reduce the signal range.

**ATTENTION**

- Turn off the main gas supply of the fireplace during installation or maintenance of the receiver.
- Place the receiver's 3-position slider switch in the off (down) position during installation or maintenance.
- Turn off main gas supply to the fireplace prior to removing or reinserting the batteries in the receiver.

**TRANSMITTER (REMOTE CONTROL WITH LCD DISPLAY)**

The Proflame Transmitter uses a streamline design with a simple button layout and informative LCD display. See Figure 65. The Transmitter is powered by 3 AAA type batteries. A Mode Button is provided to Index between the features and a Thermostat Button is used to turn on/off or index through thermostat functions. See Figures 64 and 65.

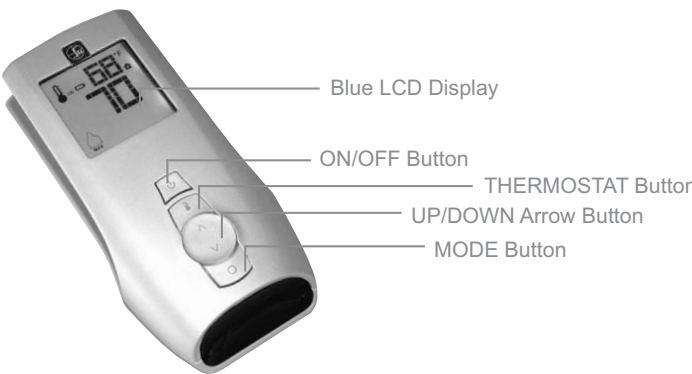


Figure 64 - Proflame Transmitter

The receiver may need to learn the transmitter. Press "learn" button on the remote receiver followed by the power ON/OFF button on the transmitter. A series of beeps will signal communication has been made.

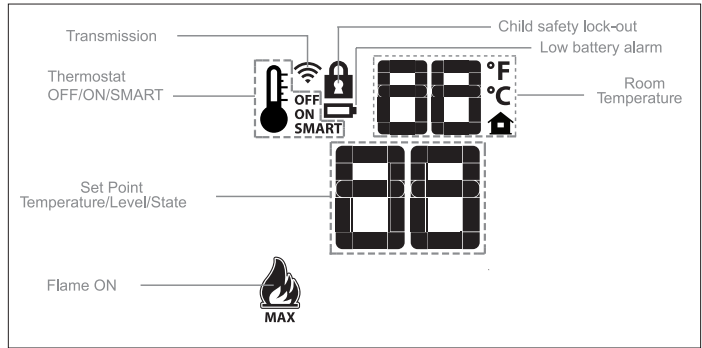


Figure 65 - Transmitter LCD display

**RECEIVER**

The Proflame Receiver Figures 66 and 67 connects directly to the gas valve and stepper motor with a wiring harness. The Receiver is powered by 4 AA type batteries. The Receiver accepts commands via radio frequency from the Transmitter to operate the fireplace in accordance with the particular Proflame system configuration. The Receiver three position slider switch can be set to one of three positions: Up for ON (Manual Override), middle for Remote (Remote control) or down for OFF.

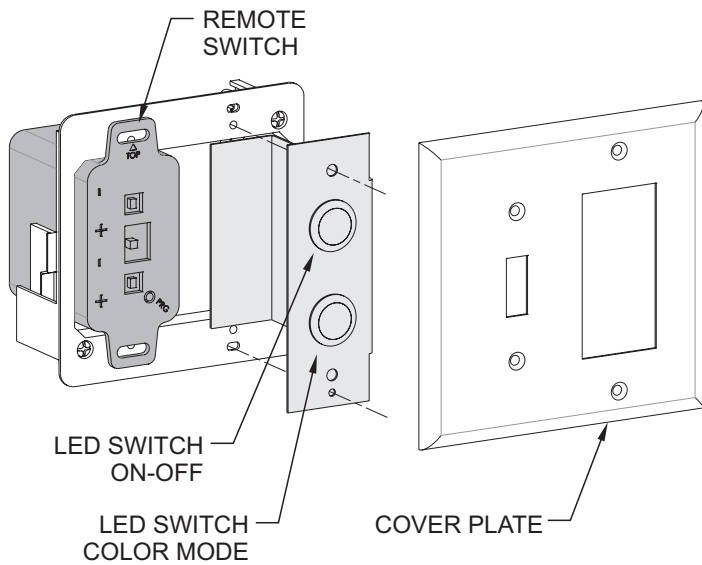


Figure 66 - Proflame Receiver Body Front

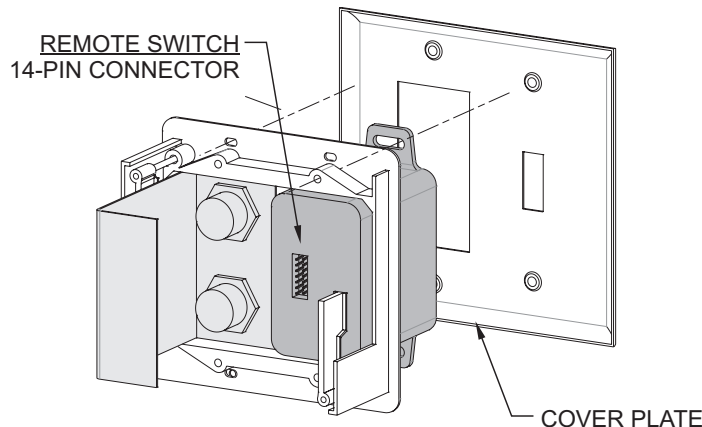


Figure 67 - Proflame Receiver Body Back

# PROFLAME - IP CONTROL SYSTEM (CONT'D)

## INITIALIZING THE SYSTEM

Install 4 AA batteries into the receiver located behind the wall plate. **See Figure 67.** Note the polarity of battery and insert into the battery bay as indicated on the Battery cover (+/-). Place the 3 position slider switch in the Remote position.

Insert paper clip, or other similar object into the hole marked PRG on the receiver front cover. The receiver will beep three times to indicate that it is ready to synchronize with a transmitter. Install the 3 AAA type batteries in the transmitter. Push the ON button. The receiver will beep four times to indicate the transmitter's command is accepted and sets to the particular code of that transmitter. The system is now initialized.

## TEMPERATURE INDICATION DISPLAY

With the system OFF, press the Thermostat Button and the Mode Button at the same time. Verify that a C or F is visible to the right of the Room Temperature display. **See Figures 68 and 69.**

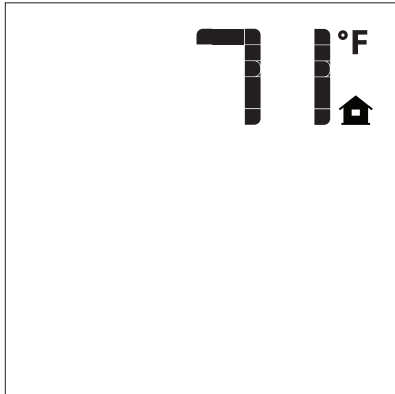


Figure 68 - Fahrenheit

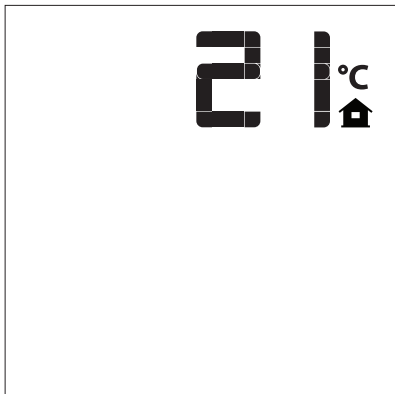


Figure 69 - Celsius

## TURN ON THE FIREPLACE

Press the ON/OFF Button. The Transmitter display will show all active Icons on the screen. The fireplace main burner turns on. A single beep from the Receiver will confirm reception of the command.

## TURN OFF THE FIREPLACE

Press the ON/OFF Button on the Transmitter. The Transmitter LCD display will only show the room temperature and Icon. **See Figure 70.** The fireplace burner turns off. A single beep from the Receiver confirms reception of the command.

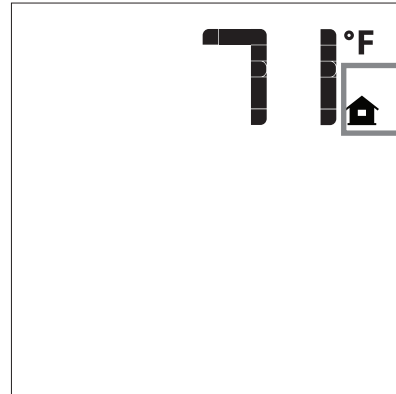


Figure 70

# PROFLAME - IP CONTROL SYSTEM (CONT'D)

## REMOTE FLAME CONTROL

The remote has six flame levels. With the system on, and the flame level at maximum, each time you press the down arrow button will reduce the flame height by one step until the flame is turned off. Pushing the up arrow button will increase the flame height each time it is pressed. Pushing the up arrow button while the system is on but the flame is off will light the burner, the flame will come on in the high position. See Figures 71 and 72. A single beep confirms receipt of the command.

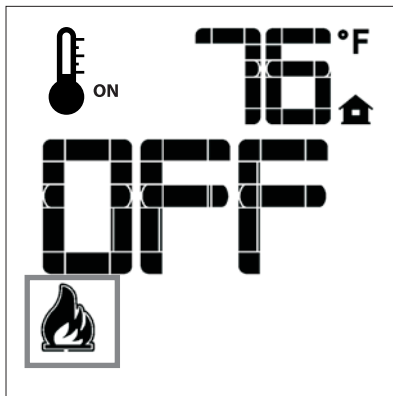


Figure 71

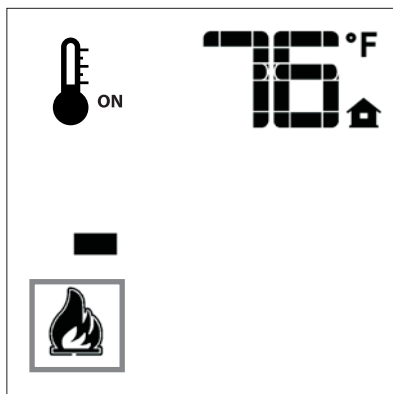


Figure 72

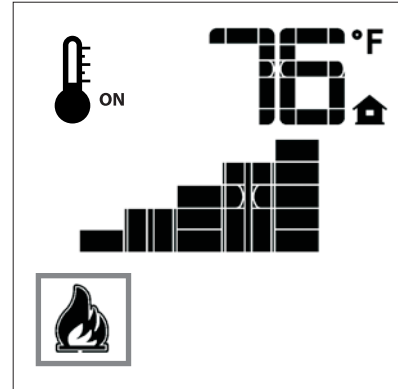


Figure 73

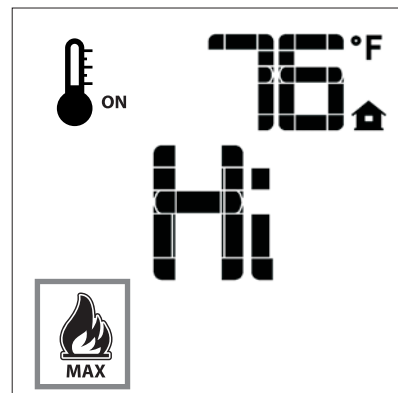


Figure 74

# PROFLAME - IP CONTROL SYSTEM (CONT'D)

## THERMOSTAT OPERATION

The Remote Control can operate as a room thermostat. The thermostat can be set to a desired temperature to control the comfort level in a room.

To activate this function, press the Thermostat Button. **See Figure 64.** The LCD display on the Transmitter will change to show that the room thermostat is ON and the set temperature is now displayed. **See Figures 76 and 77.** To adjust the set temperature, press the Up or Down Arrow Buttons until the desired set temperature is displayed on the LCD screen of the Transmitter.

## SMART THERMOSTAT (TRANSMITTER OPERATION)

The Smart Thermostat function adjusts the flame height in accordance to the difference between the set point temperature and the actual room temperatures. As the room temperature gets closer to the set point the Smart Function will modulate the flame down.

To activate this function, press the Thermostat Button **Figure 64** until the word SMART appears to the right of the temperature bulb graphic. **See Figure 77.** To adjust the set temperature, press the Up or Down arrow Buttons until the desired set point temperature is displayed on the LCD screen of the Transmitter. **See Figure 78.**

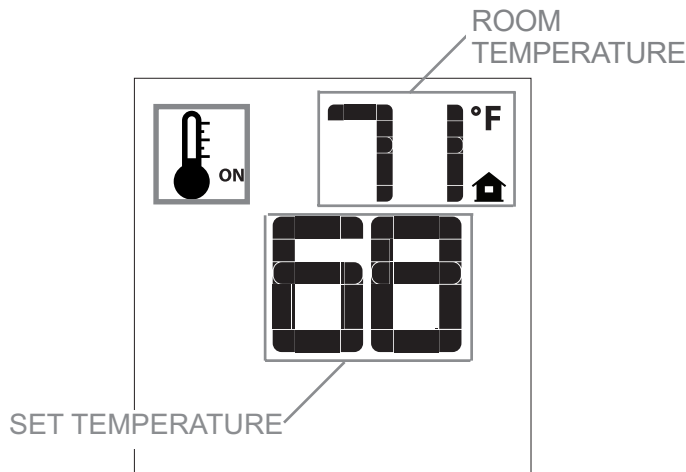


Figure 75

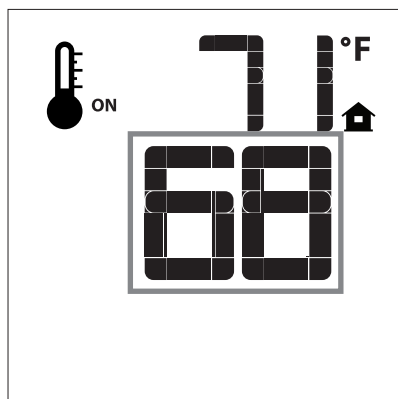


Figure 76

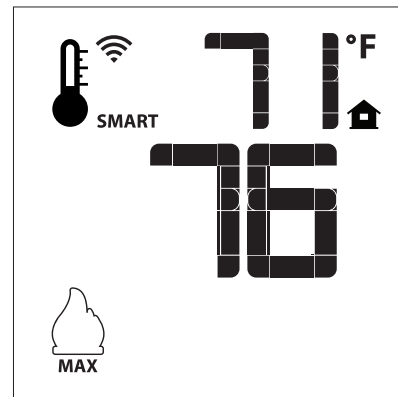


Figure 77

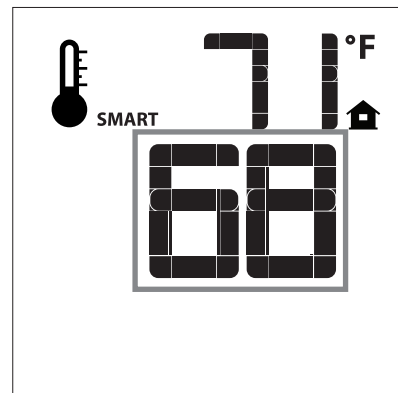


Figure 78

# PROFLAME - IP CONTROL SYSTEM (CONT'D)

## BUTTON LOCK

This function will lock the buttons to prevent unsupervised operation. To lock the remote, press the MODE and the UP arrow button at the same time. See Figure 79.

To unlock the remote, press the MODE and the UP arrow button at the same time.

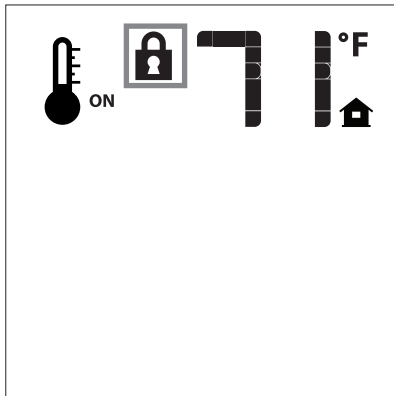


Figure 79

## LOW POWER BATTERY INDICATOR\_TRANSMITTER

When the Transmitter batteries are low, a battery icon will appear on the LCD display. See Figure 80. Replace the batteries and the icon will disappear. See page 49 to change batteries in remote switch.

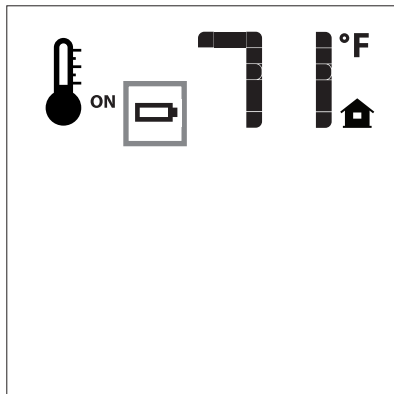


Figure 80

## RECEIVER

When the receiver batteries are low, no beep will be emitted when it receives an ON/OFF command from the transmitter. Replace the batteries.

## MANUAL BYPASS OF THE REMOTE SYSTEM

If the batteries of the receiver or transmitter die, you can still operate the fireplace manually by sliding the three position slider switch on the wall control to the ON position.

This will bypass the remote control feature of the system and the fireplace main burner will come on.

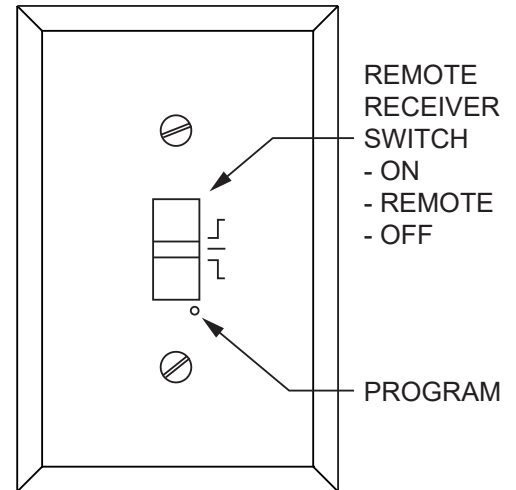


Figure 81

# WIRING DIAGRAM - MILLIVOLT CONTROL SYSTEM

Label all wires prior to disconnection when servicing controls. Wiring errors can cause improper and dangerous operation. Verify proper operation after servicing.

Millivolt thermopile is self powered, gas valve does not require 110 volts. Maximum length of 20 feet of 16 AWG to conductor wires is to be used with all optional switches.

## Check 750 Millivolt System Operation

Millivolt system and all individual components may be checked with a millivolt meter 0-1000 MV range. The thermopile reading needs to be between 325 and 400 millivolts.

## Remote Receiver

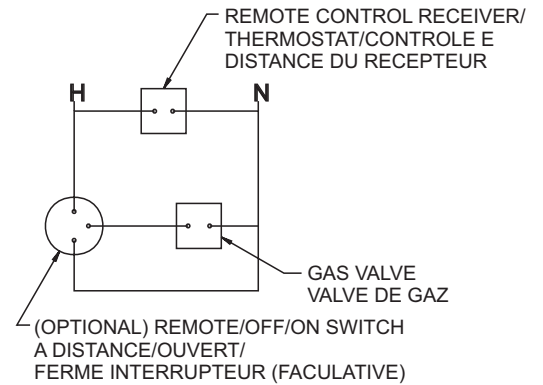
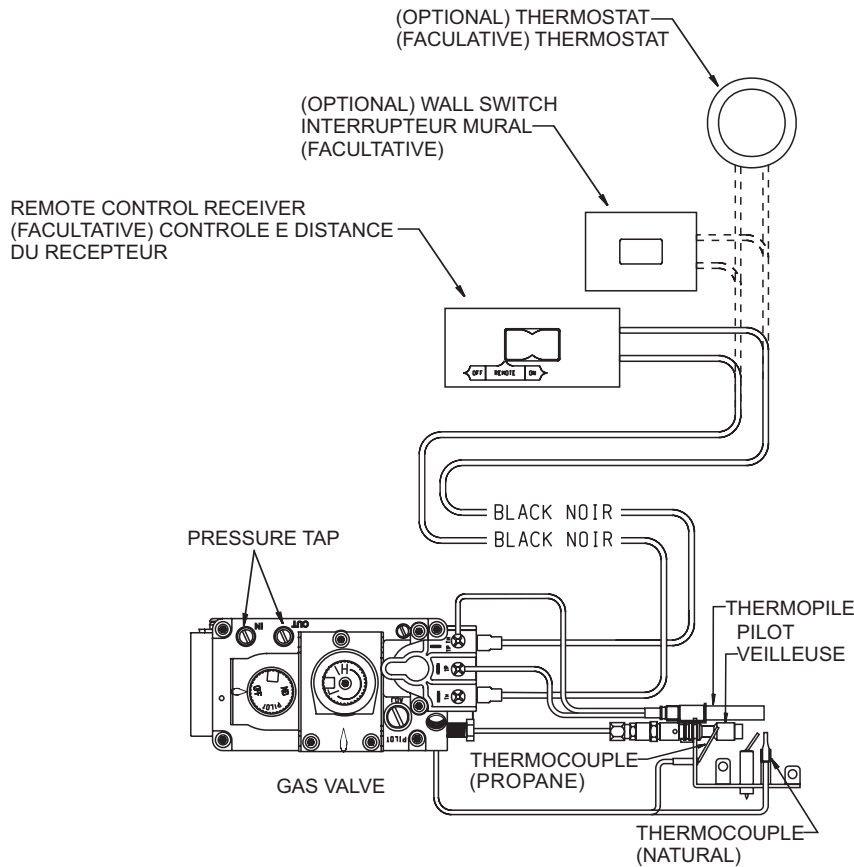
Use the following steps to place the remote receiver adjacent to the gas valve.

**ATTENTION:** The remote receiver bracket is not used in this installation.

1. The remote receiver can not be placed beside the gas valve and burner assembly.
2. When facing the fireplace, the remote receiver must be placed to the left of the gas valve.

Refer to remote control installation and operating instructions for more details on remote control.

## WIRING DIAGRAM



IF ANY OF THE ORIGINAL WIRE AS SUPPLIED WITH THIS UNIT MUST BE REPLACED, IT MUST BE REPLACED WITH NUMBER 18, 150°C WIRE OR ITS EQUIVALENT.

SI UN DES FILS ELECTRIQUES ORIGINAUX, VENANT DU FABRICANT AVEC CETTE UNITE, DOIT ETRE REMPLACE, VOUS DEVEZ LE REMPLACER AVEC UN FIL ELECTRIQUE DE NUMERO 18, 150°C DU L'EQUIVALENT.

# FRBC - MILLIVOLT CONTROL SYSTEM

## INSTALLATION AND OPERATING INSTRUCTIONS

### INTRODUCTION

This remote control system was developed to provide safe, reliable, and user-friendly remote control system for gas heating fireplaces.

The system can be operated manually from the transmitter. The system operates on one of 255 security codes that are programmed into the transmitter at the factory.

The transmitter operates on a 12V battery (included) made specifically for remote controls and electronic lighters. Install the 12V battery supplied with the unit into the battery compartment.

### TRANSMITTER

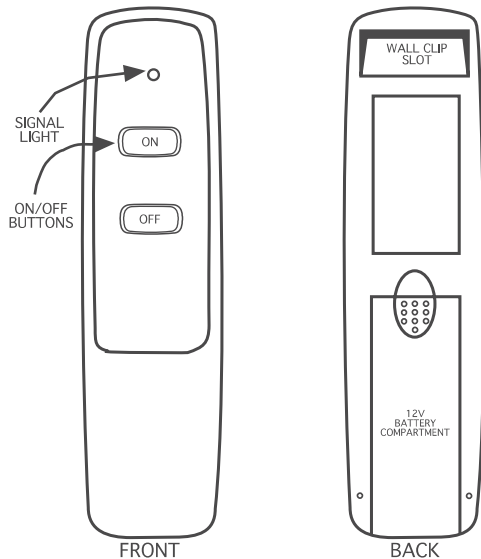


Figure 82

Always use alkaline batteries. They perform better and last longer. The transmitter has ON and OFF functions that are activated by pressing either button on the face of the transmitter. When a button on the transmitter is pressed, a signal light on the transmitter illuminates briefly to verify that a signal has been sent. Upon initial use, there may be a delay of three seconds before the remote receiver will respond to the transmitter. This is part of the system's design. If the signal light does not illuminate, check the position of the transmitter's battery.

### REMOTE RECEIVER

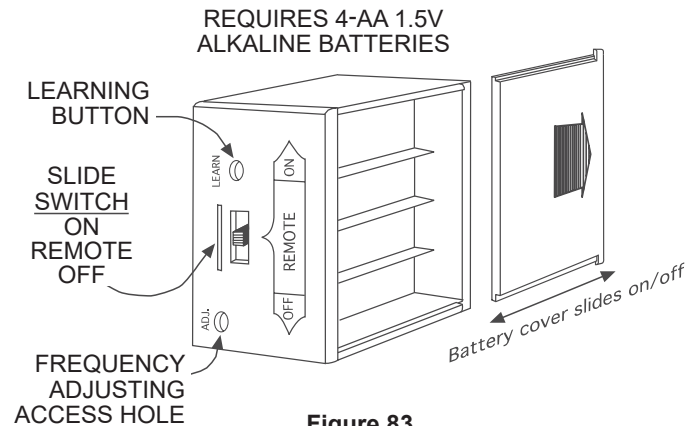


Figure 83

The remote receiver operates on 4 AA-size 1.5V batteries. It is recommended that ALKALINE batteries be used for longer battery life and maximum microprocessor performance. **IMPORTANT:** New or fully charged batteries are essential for proper operation of the remote receiver.

The remote receiver houses the microprocessor that responds to commands from the transmitter to control system operation. The remote receiver has a 3-position slide switch for selecting the MODE of operation: ON/REMOTE/OFF

- With the slide switch in the ON position (toward the LEARN button), the system will remain on until the slide switch is placed in the OFF or REMOTE position.
- With the slide switch in the REMOTE position (centered), the system will only operate if the remote receiver receives commands **from the transmitter**.
- With the slide switch in the OFF position (away from the LEARN button), the system is off.
- **It is suggested that the slide switch be placed in the off position if the homeowner will be away from home for an extended period of time. If the remote receiver is mounted out of children's reach, placing the slide switch in the OFF position also functions as a safety "lock-out" by both turning the system off and rendering the remote receiver inoperative.**

# FRBC - MILLIVOLT CONTROL SYSTEM (CONT'D)

## INSTALLATION

### **⚠ WARNING**

This remote control system must be installed exactly as outlined in these instructions. Read all instructions completely before attempting installation. Follow instructions carefully during installation. Any modifications of the ECS remote control or any of its components will void the warrant and may pose a fire hazard.

Do not connect any gas valve or electronic module directly to 110-120VAC power. Consult gas fireplace manufacturer's instructions and wiring schematics for proper placement of all wires. All electronic modules are to be wired to manufacturer's specifications.

The following wiring diagrams are for illustration purpose only. Follow instructions from manufacturer of gas valve and/or electronic module for correct wiring procedures. Improper installation of electric components can cause damage to electronic module, gas valve and remote receiver.

The remote receiver can be either wall-mounted in a standard plastic switch box or placed on or near the fireplace hearth. Preferably, the remote receiver should be wall-mounted in a plastic switch box, as this will protect its electronic components from both the heat produced by the gas fireplace and potential damage or abuse that can occur if it is left exposed on the hearth.

### **PROTECTION FROM EXTREME HEAT IS VERY IMPORTANT.**

Like any piece of electronic equipment, the remote receiver should be kept away from temperatures exceeding 130° F inside the receiver case. Battery life is also significantly shortened if batteries are exposed to high temperatures.

Make sure the remote receiver switch is in the OFF position. It is recommended that 18 gauge solid or stranded wires (not included) be used to make connections between the terminal wiring block on the millivolt gas valve or electronic module and the wire terminals on the remote receiver. For the best results, use 18 gauge solid or stranded wire, with no splices and measuring no longer than 20 ft.

## WIRING INSTRUCTIONS

A qualified electrician or a gas technician who is familiar with the gas fireplace and gas valves that will be operated by this remote should install the remote control system. Incorrect wiring connections WILL cause damage to the gas valve or electronic module operating the gas fireplace and may also damage the remote receiver.

### WIRING MILLIVOLT VALVES

The remote receiver is connected to the millivolt valve using the TH (thermostat) terminals on the terminal block on the millivolt gas valve.

Connect 18 gauge solid or stranded wires from the remote receiver to the gas valve.

Operation of the remote receiver is similar to that of a thermostat in that both turn the gas valve on and off based on input signals. A thermostat's input signals are different temperatures. The remote receiver's input signals come from the transmitter.

Connect each of the two wires leading from the TH terminals on the millivolt gas valve to either of the two wire terminals on the remote receiver. Normally it does not matter which wires go to which terminal.

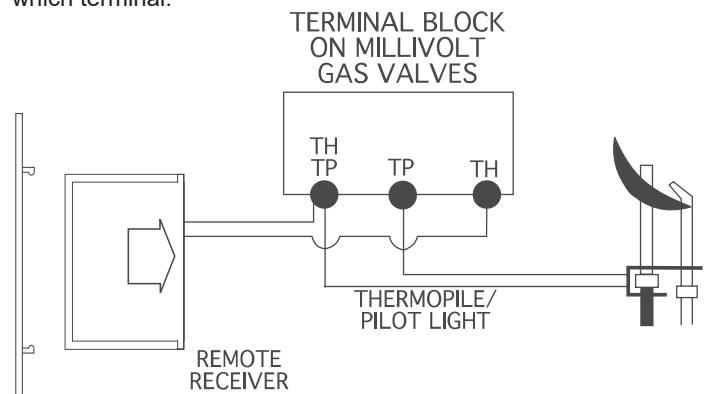


Figure 84

## SYSTEM CHECK

### Millivolt Valves

Light gas fireplace following the lighting instructions that came with the fireplace. Confirm that the pilot flame is on; it must be in operation for the main gas valve to operate.

- Slide the 3-position button on the remote receiver to the ON position. The main gas flame (i.e., the fire) should ignite.
- Slide the button to OFF. The flame should extinguish (the pilot flame will remain on).
- Slide the button to REMOTE (the center position), then press the ON button on the transmitter to change the system to ON. The main gas flame should ignite.

# FRBC - MILLIVOLT CONTROL SYSTEM (CONT'D)

## GENERAL INFORMATION

### Matching Security Codes

Each transmitter can use one of 255 unique security codes. It may be necessary to program the remote receiver to LEARN the security code of the transmitter upon initial use, if batteries are replaced, or if a replacement transmitter is purchased from the dealer or the factory. When matching security codes, be sure slide button on the receiver is in the REMOTE position; the code will NOT "LEARN" if the slide switch is in the ON or OFF position. Program the remote receiver to LEARN a new security code by pushing and releasing the learn button. A single "beep" will sound. Press the "ON" button on the remote control, until three "beeps" sound. The three "beeps" are the signal that the receiver has learned the new code. When an existing receiver is matched to a new transmitter, the new security code will override the old one.

The microprocessor that controls the security code matching procedure is controlled by a timing function. If matching the security code on the first attempt was unsuccessful, wait 1-2 minutes before trying again – this delay allows the microprocessor to reset its timer circuitry – and try up to two or three more times.

### BATTERY LIFE

Life expectancy of the alkaline batteries is longer and performance better than other batteries. Check and replace all batteries annually. When the transmitter no longer operates the remote receiver from a distance it did previously (i.e., the transmitter's range has decreased) or the remote receiver does not function at all, the batteries should be checked. It is important that the remote receiver batteries are fully charged and provides continuous output voltage of a least 5.3 volts. The length of the wire between the remote receiver and gas valve directly affects the operating performance of the remote system. The longer the wire, the more battery power is required to deliver signals between the remote receiver and the gas valve. Recommended length is no longer than 20 feet. The transmitter should operate with as little as 5.0 volts battery power.

### TROUBLE SHOOTING

If problems with the fireplace system occur, the cause may be with the fireplace itself or it could be with the ECS remote. Review the fireplace manufacturer's operation manual to make sure all connections are properly made. Then check the operation of the ECS remote in the following manner:

- Make sure the batteries are correctly installed in the RECEIVER. One reversed battery will keep receiver from operating properly.
- Check battery in Transmitter to make sure contacts are touching (+) and (-) ends of battery. Bend metal contacts in for tighter fit.
- Be sure RECEIVER and Transmitter are within 20'-25' operating range.
- Keep RECEIVER from temperatures exceeding 130° F. Battery life shortened when ambient temperatures are above 130° F.
- If RECEIVER is installed in tightly enclosed metal surround, the operating distance will be shortened.

## RECEIVER ADJUSTMENT – RECOMMENDED ADJUSTMENT

**NOTE:** The slide button, White or Black, covers the ADJ access hole when installed.

- To adjust at the receiver, use a small slotted screwdriver. Turn the adjustment screw counter-clockwise about 5 degrees or a maximum of 1/8 turn. This should correct the distance problem.
- If that does not correct the problem, return adjustment screw to original position and then turn adjustment screw clockwise. This adjustment is like tuning a radio. If continued to be turned in either direction, the adjustment screw will go past the proper setting (tuning).

## REMOTE RECEIVER

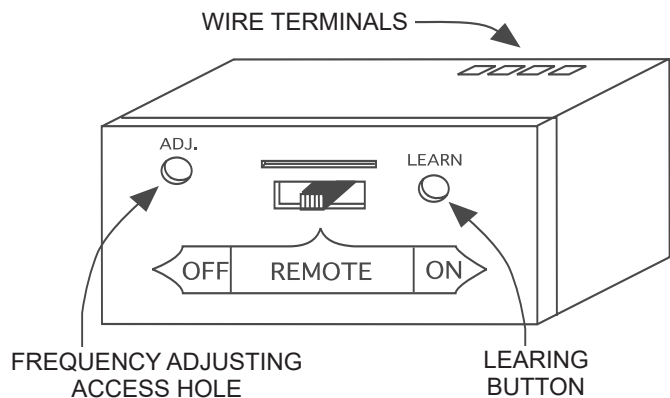


Figure 85

## SPECIFICATIONS

### Batteries:

- Transmitter 12V (A23)
- Remote Receiver
- 6V - 4ea. AA1.5 Alkaline

FCC ID No.'s: transmitter - K9L1002TX;

Receiver - K9L3001RX

Operating Frequency: 303.875MHZ

Canadian ISC ID No.'s: transmitter - 2439 102 728;

Receiver - 2439 102 728A

### FCC REQUIREMENTS

**NOTE:** The Manufacturer Is Not Responsible For Any Radio Or Tv Interference Caused By Unauthorized Modifications To This Equipment. Such Modifications Could Void The User's Authority To Operate The Equipment.

# CLEANING AND SERVICING

Annual inspection and cleaning by the dealer or qualified service technician is recommended to prevent malfunction.

**TURN OFF FIREPLACE AND ALLOW TO COOL BEFORE CLEANING.**

Remove any optional decorative covers or decorative glass material. Gloves are recommended.

**PERIODIC CLEANING - Refer to parts diagram for location of items discussed below.**

- Do not use cleaning fluid to clean any part of fireplace.
- Clean glass with ammonia-free cleaner. Ammonia will etch or stain glass when heated. (We recommend gas fireplace glass cleaner.)
- Remove loose particles and dust from the burner, controls and air shutter.
- Inspect and clean burner air intake hole. Remove lint or particles with brush. Failure to keep air intake hole clean will result in sooting and poor combustion.

**ANNUAL CLEANING/INSPECTION - Refer to parts diagram for location of items discussed below.**

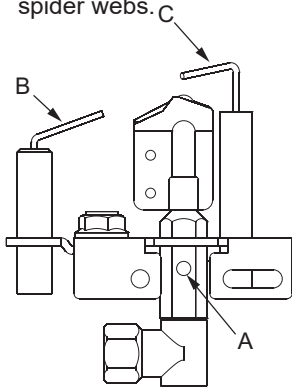
- Inspect and clean burner air intake hole. Remove lint or particles with vacuum or brush. Failure to keep air intake hole clean will result in sooting and poor combustion.
- Inspect and clean all burner ports.
- Inspect ODS pilot for operation and accumulation of lint at air intake holes.
- Verify flame pattern for proper operation.
- Verify smooth and responsive ignition of main burner.

## PILOT MAINTENANCE AND CLEANING

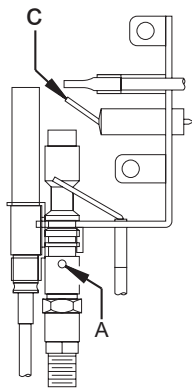
### Oxygen Depletion Sensor Pilot

When the pilot has a large yellow tip flame, clean the Oxygen Depletion Sensor as follows:

1. Use canned air to blow through hole A. See Figures 86 and 87. This will blow out foreign materials such as dust, lint and spider webs.



Intermittent Pilot  
Figure 86



Millivolt Pilot  
Figure 87

2. If intermittent pilot fireplace stops working, clean flame sensor B Figure 86 with a damp cloth.
3. If intermittent pilot ignitor does not spark, clean ignitor C Figure 86 with a damp cloth.

## CONTROL COMPARTMENT AND BURNER MAINTENANCE

Keep the control compartment and burner area clean by vacuuming or brushing area at least twice a year.

### WARNING

**The fireplace can get very hot. Handle only when cool.**

Always turn off gas to the pilot before cleaning. For relighting, refer to lighting instructions located on the rating plate.

Never obstruct the flow of the combustion and ventilation air. Keep the front of the fireplace clear of all obstacles.

## BATTERY REPLACEMENT

An intermittent pilot may require more frequent battery changes.

To replace the batteries, follow these steps:

1. Remove the cover from the electrical box on the wall.
2. Replace the batteries inside the box.
3. Replace the cover using four (4) #4 x 1/2 Phillips screws.

**To replace the batteries for a Millivolt model, follow these steps:**

1. Remove the barrier screen assembly. See page 34.
2. Remove the optional glass media from inside the fireplace.
3. Lift and set aside the burner cover.
4. Lift the remote receiver.
5. Replace the four AA batteries.
6. Replace the items removed in steps 1 through 4.

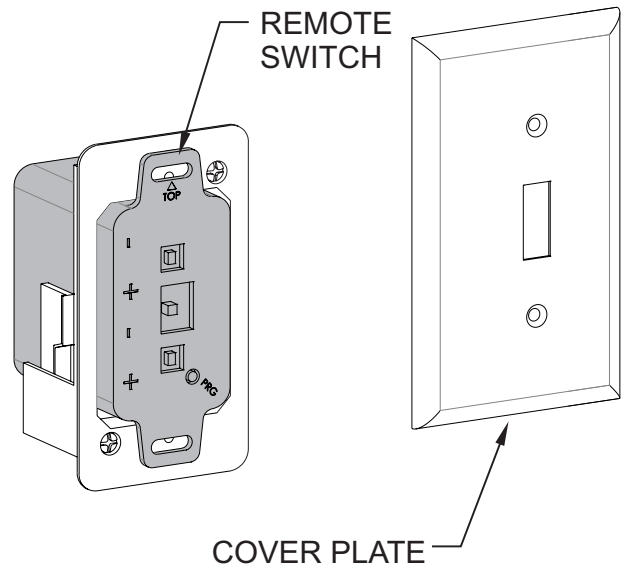


Figure 88 - IP Remote Receiver

### WARNING

**Never use needles, wires, or similar cylindrical objects to clean the pilot to avoid damaging the calibrated ruby that controls the gas flow.**

# TROUBLESHOOTING - IP CONTROL SYSTEM

## BRIEF DESCRIPTION OF THE COMPONENTS

The Digital Fireplace Control (DFC) is an automatic gas ignition system based on a single micro-controller core. This control manages all functions related to ignition, flame sensing and supervision for atmospheric applications.

The DFC can be set to provide continuous or intermittent ignition control sequences and flame monitoring with safety shutdown in case of failure.

The DFC is set up as a standalone (AC powered system with battery backup). See IP Lighting Instructions on page 35 and Wiring Diagram on page 24.

## TROUBLESHOOTING

Before proceeding with the procedures in the following troubleshooting table, verify that the power supply (AC/DC adapter) is present and that the batteries inside the remote switch and remote control are fresh and installed with correct polarity.

Make sure all the connections between the wire harnesses and system components are proper and positive.

Verify that the static inlet pressure meets the manufacturer's recommended inlet pressure. If necessary adjust the line pressure regulator.

If the recommended actions for the following troubleshooting chart do not help to address the problem consider replacing wiring harnesses.

### WARNING

**Any actions performed on the gas valve must be performed in accordance with this instruction manual. Likewise, any actions performed on the DFC or other system components must be done in accordance with the individual component instructions. Replacement of components must be performed in accordance with this instructions manual.**

# TROUBLESHOOTING - IP CONTROL SYSTEM (CONT'D)

PROBLEM OBSERVED	POSSIBLE CAUSE	CORRECTIVE MEASURE
Gas odor during setup	Gas Leak	<b>What To Do If You Smell Gas</b> Do not try to light any appliance. Do not touch any electrical switch; Do not use any phone in your building. Immediately call your gas supplier from a neighbor's phone. Follow the gas supplier's instructions. If you cannot reach your gas supplier, call the fire department.
Gas odor before first ignition	Gas Leak	
Fireplace is on but no flame and pilot is not trying to light	Gas Line Valve turned off	Turn shut-off valve to open position.
	Control module in lockout	Turn power to fireplace off and then back on.
Pilot continues to spark when pilot is lit	Not enough gas to pilot	Wait for pilot flame to strengthen.
	Low Gas Pressure	Check pressures. See page 20.
	Pilot igniter/sensor is dirty	Clean pilot. See maintenance homeowner manual.
	Pilot not grounded well	Check ground connections.
	Draft in firebox	Redirect draft from room or wall.
	Pilot sensor has been bent	Replace pilot.
Pilot will not ignite, or will not stay lit	Pilot igniter/sensor is dirty	Clean flame sensor and pilot igniter. See maintenance homeowner manual.
	Pilot not grounded well	Check ground connections.
	Sensor Wire loose	Check sensor wire terminals.
	Gas pressure incorrect	Adjust gas pressure.
	Pilot Gas Line bent or kinked	Replace pilot tube.
	Faulty pilot, Sensor bent	Replace Pilot.
	Faulty valve	Replace Valve.
Burner takes too long to fully light	Low gas pressure	Check gas supply pressure.
	Clogged or dirty carryover/burner ports	Clean ports.
	Blocked orifice	Check orifice opening.
	Faulty valve	Replace valve.
Burner does not light but pilot remains on	Low gas pressure	Check gas supply pressure.
	Clogged or dirty burner ports	Clean burner ports.
	Blocked orifice	Check orifice opening.
	Loose wire connections	Check valve/control module connections.
	Faulty pilot	Replace pilot.
	Faulty valve	Replace valve.

# TROUBLESHOOTING - IP CONTROL SYSTEM (CONT'D)

PROBLEM OBSERVED	POSSIBLE CAUSE	CORRECTIVE MEASURE
Burner lights but does not stay lit while pilot remains on	Low gas pressure	Check gas supply pressure.
	Loose sensor wire	Check wire connection.
	Faulty valve	Replace valve.
	Faulty pilot or thermocouple	Replace Safety pilot.
	Clogged or dirty burner ports	Clean burner ports.
	Room temperature is higher than thermostat setting	Move remote away from fireplace.
		Set higher temperature on remote/thermostat
Remote control batteries failing	Replace batteries in remote transmitter and receiver.	
Burner and pilot light but will not stay lit	Flame sensor dirty	Clean pilot sensor.
	Low gas pressure	Check gas supply pressure.
	Not enough fresh air for pilot	Open door or window - ventilate.
	Clogged or dirty burner ports	Clean burner ports.
	(For fireplace equipped with optional thermostat or thermostat remote) Room temperature is higher than thermostat setting	Move (optional) remote away from fireplace.
		Set higher temperature on (Optional) remote/thermostat.
	If using Propane Gas, verify pilot bracket is not installed. Pilot bracket if included, will be outside of burner box to the right and above the pilot.	Remove pilot bracket.
	Remote control batteries failing	Replace batteries in remote transmitter and receiver.
Faulty pilot or thermocouple	Replace pilot	
Incorrect burner flame	Incorrect gas supply or pressure	Check gas supply pressure.
	Blocked orifice	Check orifice opening.
	Clogged or dirty burner ports	Clean burner ports.
	Faulty valve	Replace valve.
	High altitude	Adjust orifice size for altitude.
Backfire of burner	Blocked orifice	Check orifice opening.
	Clogged or dirty burner ports	Clean burner ports.
	Low gas pressure	Check gas supply pressure.
Fireplace produces unwanted odors	Vapors from paint, hairspray, glue, etc.	Ventilate room until odor stops. Do not use paint, hairspray, glue, etc around fireplace.
	Initial burn-off of manufacturing chemicals	Ventilate room until odor stops.
Whistle noise from fireplace	Check gas pressure	Adjust gas pressure to recommended setting.
	Air in gas line	Bleed lines.
	Control knob not in fully open position	Open control knob to full position.
	Spiral gas flex line pinched or too small diameter line	Straighten flex line where pinched or replace gas feed line with larger diameter.

# TROUBLESHOOTING - MV CONTROL SYSTEM

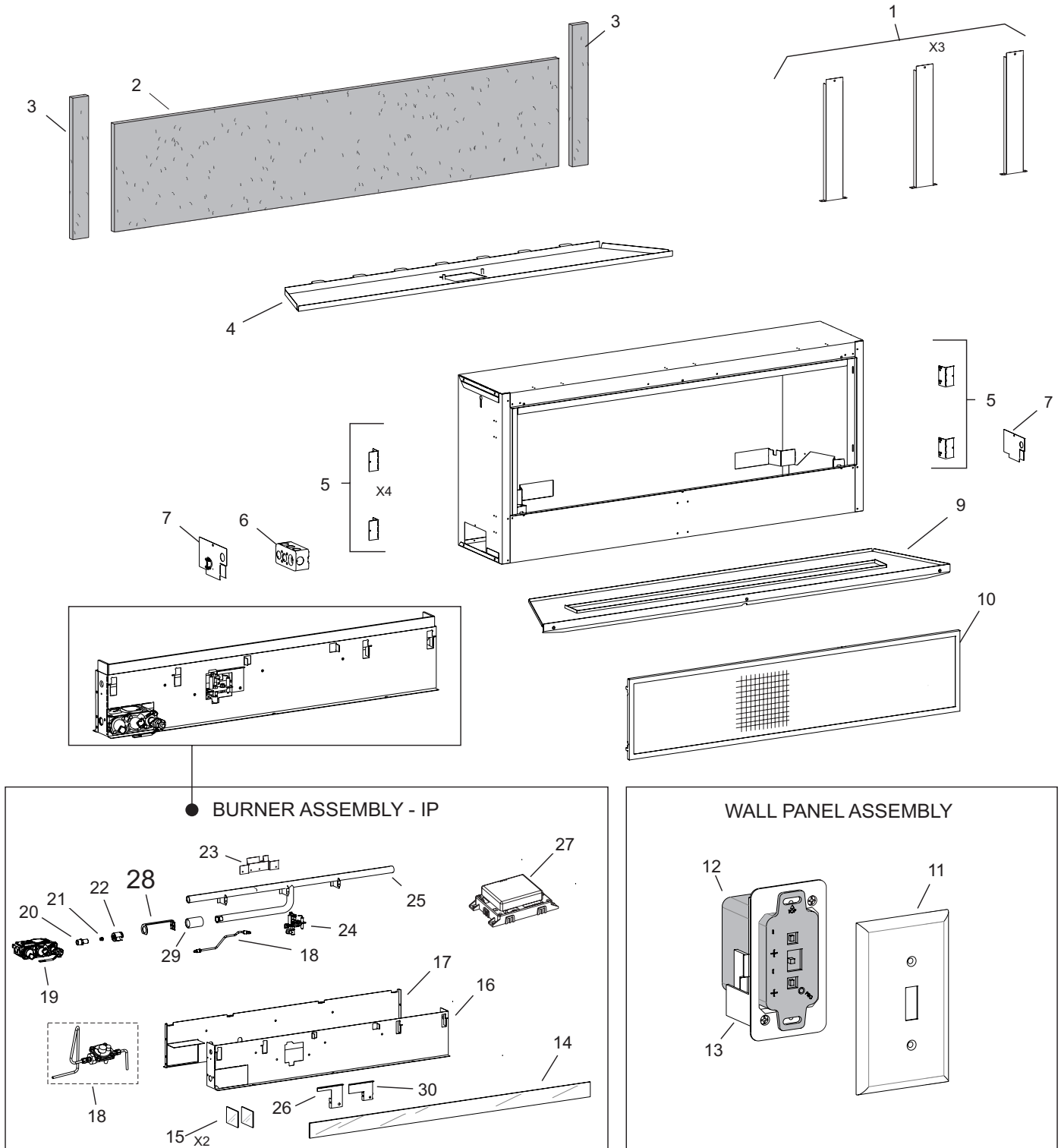
PROBLEM OBSERVED	POSSIBLE CAUSE	CORRECTIVE MEASURE
When ignitor button is pressed, there is no spark at ODS/pilot.	Ignitor electrode positioned wrong	Replace pilot.
	Ignitor electrode is broken	Replace pilot.
	Ignitor electrode not connected to ignitor cable	Reconnect ignitor cable.
	Ignitor cable pinched or wet. Keep ignitor cable dry.	Free ignitor cable if pinched by any metal or tubing.
	Broken ignitor cable	Replace ignitor cable.
	Bad piezo ignitor	Replace piezo ignitor.
Fireplace produces unwanted odors	Fireplace burning vapors from paint, hair spray, glues, etc.	Ventilate room. Stop using odor causing products while fireplace is running.
	Gas leak	Locate and correct all leaks.
Fireplace shuts off during use. (Pilot and main burner are off.)	Not enough fresh air is available for ODS pilot to operate	Open window and/or door for ventilation.
	Low Line Pressure	Contact local gas company.
	ODS/pilot is partially clogged	Clean ODS/pilot.
	Defective thermocouple	Replace pilot.
Fireplace shuts off during use. (Pilot stays on.)	Low line pressure	Check line pressure to the valve.
	Defective thermopile	Check pilot flame, check wire connections, output should be a minimum of 325 millivolts across. TH/TP and TP terminals with REMOTE/OFF/ON switch off.
Gas odor even when control knob is in OFF position	Gas leak	Locate and correct all leaks.
	Control valve defective	Replace control valve.
When ignitor button is pressed, there is spark at ODS/pilot, but no ignition	Gas supply turned off or manual shut-off valve closed	Turn on gas supply or open manual shut-off valve.
	Control knob not in PILOT position	Turn control knob to PILOT position.
	Control knob not pressed in while in PILOT position	Press in control knob while in PILOT position.
	Air in gas lines when installed	Continue holding down control knob. Repeat igniting operation until air is removed.
	ODS/pilot is clogged	Replace ODS/pilot assembly or get it serviced.
	Gas regulator setting is not correct	Replace gas regulator.

# TROUBLESHOOTING - MV CONTROL SYSTEM (CONT'D)

PROBLEM OBSERVED	POSSIBLE CAUSE	CORRECTIVE MEASURE
ODS/pilot lights but flame goes out when control knob is released	Control knob not fully pressed in	Press in control knob fully.
	Control knob not pressed in long enough	After ODS/pilot lights, keep control knob pressed in 30 seconds.
	Manual Shut-off valve not fully open	Fully open manual shut-off valve.
	Thermocouple connection loose at control valve	Hand tighten until snug, then tighten 1/4 turn more.
	Pilot flame not touching thermocouple, which allows thermocouple to cool, causing pilot flame to go out. This problem could be caused by either low gas pressure or dirty or partially clogged ODS/pilot.	Contact local gas company.
	Thermocouple damaged	Replace thermocouple.
	Control valve damaged	Replace control valve.
Burner does not light after ODS/pilot is lit	Burner orifice clogged	Clean burner or replace main burner orifice.
	Burner orifice diameter is too small	Replace burner orifice.
	Inlet gas pressure is too low	Contact qualified service person.
If burning at main burner orifice occurs (a loud, roaring blow torch noise)	You must turn off burner assembly	Contact a qualified service person.
	Manifold pressure is too low	Contact local gas company.
	Burner orifice clogged	Clean burner or replace burner orifice.
Fireplace produces a whistling noise when main burner is lit	Turning control knob to HIGH position when main burner is cold	Turn control knob to LOW position and let warm up for a minute.
	Air in gas line	Operate burner until air is removed from line. Have gas line checked by local gas company.
	Dirty or partially clogged burner orifice	Clean burner or replace burner orifice.

If the gas quality is bad, the pilot may not stay lit, the burners may produce soot and the fireplace may backfire when lit. If the gas quality or pressure is low, contact the local gas supplier immediately.

# VFLB(36,48)FP90 - EXPLODED VIEW



## ⚠ WARNING

Failure to position the parts in accordance with these diagrams or failure to use only parts specifically approved with this heater may result in property damage or personal injury.

# VFLB(36,48)FP90 - PARTS LIST

INDEX NO.	PART NO.		DESCRIPTION
	VFLB36FP	VFLB48FP	
1	36787	36787	Standoff Bracket (3 Required)
2	40223	40224	Non-Combustible Board - Top
3	40222	40222	Non-Combustible Board - Side (2 Required)
4	44289	44304	Inner Firebox Top Assembly
5	42261	42261	Nailing Flange (4 Required)
6	R3490	R3490	Junction Box
7	40187	40187	Junction Box Access Plate
9	40114	40115	Burner Cover Assembly
10	40309	40310	Barrier Screen Assembly
11	N/A	N/A	Wall Plate *C
12	R11235	R11235	Remote Receiver
13	N/A	N/A	Wall Plate *D
14	R12695	R11747	Glass - Burner
15	R12432	R12432	Glass Side Burner (2 Required)
16	46109	46111	Burner Box - Front
17	40104	40105	Burner Box - Back
18	40113	40113	Pilot Tube Assembly (Propane Only) *A*B
18	44428	44428	Regulator Replacement Kit (NAT, IP)
19	R11234	R11234	Valve - Propane
19	R11233	R11233	Valve - Natural
20	P313	P313	Fitting - Orifice Holder
21	P258	P250	Orifice - Propane
21	P257	P243	Orifice - Natural
22	R7624	R7624	Air Shutter
23	34440	34440	Pilot Bracket
24	R11327 2019	R11327 2019	Pilot - Propane
24	R11328 2019	R11328 2019	Pilot - Natural
25	R12664	R12665	Burner Tube Assembly
26	37482	37482	Pilot Shield (Natural Only)
27	R12907	R12907	Control Module - Proflame
28	31234	NONE	Venturi Target (36 Natural Only)
29	P251	NONE	Coupling (36 Natural Only)
30	40110	40110	Pilot Shield (Propane Only)
N/S	R11597	R11597	Tubing Ferrule - Pilot N/S
N/S	R11598	R11598	Tubing Nut - Pilot
N/S	R1978	R1978	Tubing Nut & Ferrule - Valve

INDEX NO.	PART NO.		DESCRIPTION
	VFLB36FP	VFLB48FP	
N/S	B100100	B100100	Fitting - 3/8 Flare to 3/8 Pipe
N/S	R7591	R7591	Flex Line
N/S	R11128	R11128	Power Adaptor, 7.0 VDC
N/S	R11123	R11123	Control Module Harness
N/S	R11237	R11237	Receiver Harness
N/S	R11973	R11973	Receiver Harness Extension
N/S	R11236	R11236	Remote
N/S	R11332	R11332	Flame Sensor Wire
N/S	R11333	R11333	Ignitor Wire
N/S	R3492	R3492	Receptacle
N/S	R3491	R3491	Junction Box Cover

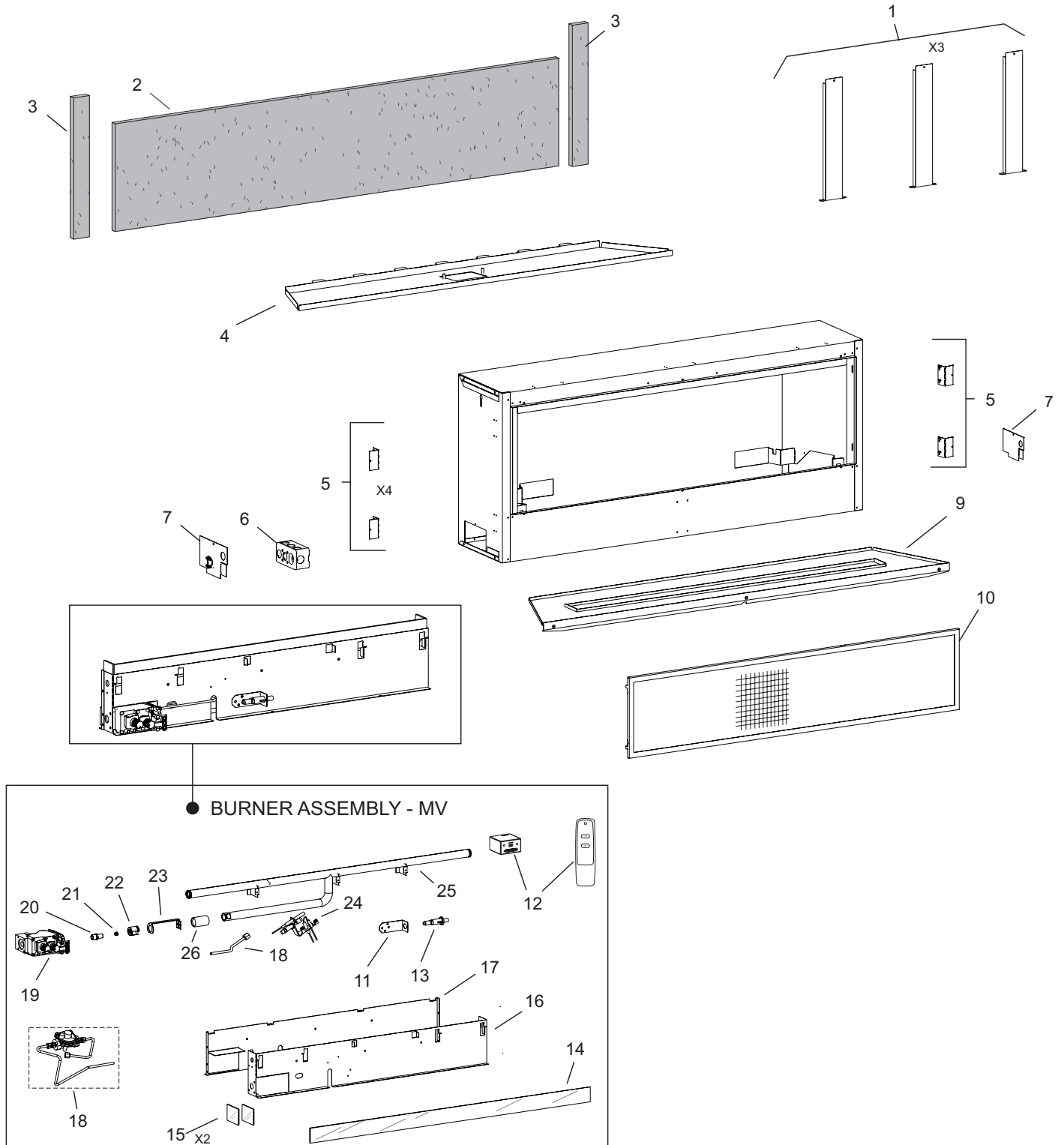
\*A Also requires R11597 and R11598.

\*B Also requires R1978.

\*C Included with R11235.

\*D Wall box not supplied.

# VFLB(36,48)FP30 - EXPLODED VIEW



## ⚠ WARNING

Failure to position the parts in accordance with these diagrams or failure to use only parts specifically approved with this heater may result in property damage or personal injury.

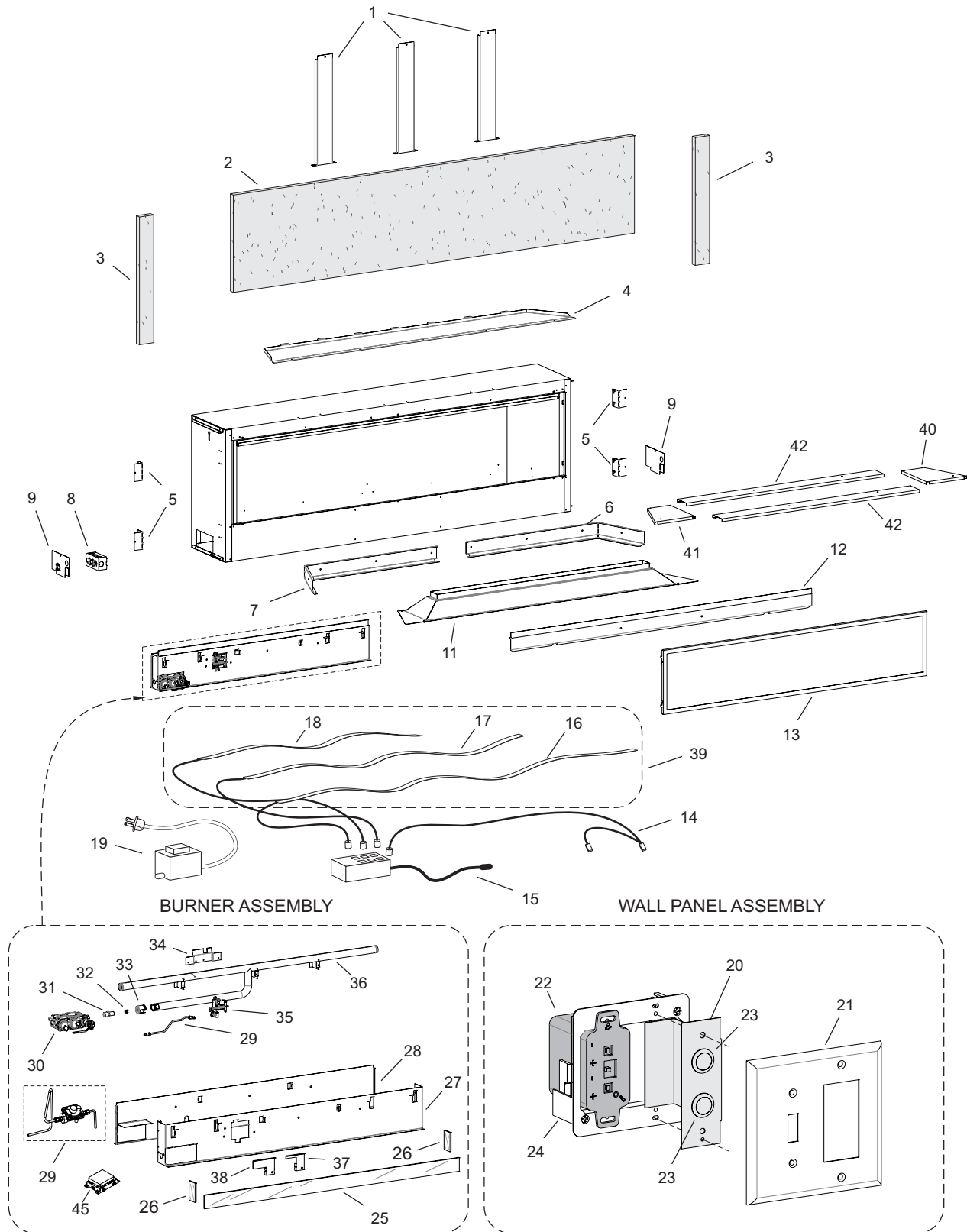
# VFLB(36,48)FP30 - PARTS LIST

INDEX NO.	PART NO.		DESCRIPTION
	VFLB36FP	VFLB48FP	
1	36787	36787	Standoff Bracket (6 Required)
2	40223	40224	Non-Combustible Board - Top
3	40222	40222	Non-Combustible Board - Side (2 Required)
4	44289	44304	Inner Firebox Top Assembly
5	42261	42261	Nailing Flange (4 Required)
6	R3490	R3490	Junction Box
7	40187	40187	Junction Box Access Plate
9	40114	40115	Burner Cover Assembly
10	40309	40310	Barrier Screen Assembly
11	26304	26304	Ignitor Bracket
12	FRBC	FRBC	Transmitter And Receiver
13	R9760	R9760	Piezo Ignitor
14	R12695	R11747	Glass - Burner
15	R12432	R12432	Glass Side Burner (2 Required)
16	46108	46110	Burner Box - Front
17	40104	40105	Burner Box - Back
18	40388	40388	Pilot Tube Assembly (Propane Only) *A
18	44426	44426	Regulator Replacement Kit (NAT, MV)
19	R3625	R3625	Valve - Propane
19	R3626	R3626	Valve - Natural
20	P313	P313	Fitting - Orifice Holder
21	P258	P250	Orifice - Propane
21	P257	P243	Orifice - Natural
22	R7624	R7624	Air Shutter
23	31234	NONE	Venturi Target (36 Natural Only)
24	R3623	R3623	Pilot - Propane
24	R3624	R3624	Pilot - Natural
25	R12664	R12665	Burner Tube Assembly
26	P251	P251	Coupling (36 Natural Only)
N/S	R1978	R1978	Tubing Nut & Ferrule - Valve
N/S	B100100	B100100	Fitting - 3/8 Flare to 3/8 Pipe
N/S	R7591	R7591	Flex Line
N/S	R5668	R5668	Ignitor Wire

INDEX NO.	PART NO.		DESCRIPTION
	VFLB36FP	VFLB48FP	
N/S	R3492	R3492	Receptacle
N/S	R3491	R3491	Junction Box Cover

\*A Also requires R1978.

# VFLB(60,72)FP90 - EXPLODED VIEW



## ⚠ WARNING

Failure to position the parts in accordance with these diagrams or failure to use only parts specifically approved with this heater may result in property damage or personal injury.

# VFLB(60,72)FP90 - PARTS LIST

INDEX NO.	PART NO.		DESCRIPTION
	VFLB60FP	VFLB72FP	
1	36787	36787	Standoff Bracket (3 Required)
2	40225	40226	Non-Combustible Board - Top
3	40222	40222	Non-Combustible Board - Side (2 Required)
4	44324	44336	Inner Firebox Top
5	42261	42261	Nailing Flange (4 Required)
6	40202	40203	Reflector Rear - Right
7	40204	40205	Reflector Rear - Left
8	R3490	R3490	Junction Box
9	40187	40187	Junction Box Access Plate
11	40189	40190	Reflective Burner Cover Assembly
12	40195	40197	Reflector Front Assembly
13	40311	40312	Barrier Screen Assembly
14	R12294	R12294	Wire Harness - Switches
15	R13283	R13283	Control Module - LED
16	R11918	R11986	LED Lighting Strip - Front
17	R11918	R11918	LED Lighting Strip - Rear Right
18	R11918	R11986	LED Lighting Strip - Rear Left
19	R11920	R11920	Transformer - LED
20	43687	43687	Bracket - LED Buttons
21	R12296	R12296	Wall Plate
22	R11235	R11235	Remote Receiver
23	R11921	R11921	Switch Button - LED (2 Required)
24	R12295	R12295	Wall Box
25	R12292	R12293	Glass - Burner
26	R12432	R12432	Glass - Side Burner (2 Required)
27	46112	46113	Burner Box - Front
28	40107	40109	Burner Box - Back
29	40113	40113	Pilot Tube Assembly (Propane Only) *A*B
29	44428	44428	Regulator Replacement Kit (NAT, IP)
30	R11234	R11234	Valve - Propane
30	R11233	R11233	Valve - Natural
31	P313	P313	Fitting - Orifice Holder
32	P304	P304	Orifice - Propane

INDEX NO.	PART NO.		DESCRIPTION
	VFLB60FP	VFLB72FP	
32	P211	P211	Orifice - Natural
33	R7624	R7624	Air Shutter
34	34440	34440	Pilot Bracket
35	R11327 2019	R11327 2019	Pilot - Propane
35	R11328 2019	R11328 2019	Pilot - Natural
36	R12666	R12667	Burner Tube Assembly
37	37482	37482	Pilot Shield (Natural Only)
37	N/A	37482	Pilot Shield (Propane Only)
38	40110	N/A	Pilot Shield (Propane Only)
39	36876	37344	LED Replacement Kit (Includes #16,17,18)
40	36784	36812	Glass Support Right
41	36785	36813	Glass Support Left
42	36786	36814	Glass Support Center (2 Required)
45	R12907	R12907	Control Module - Proflame
N/S	R11597	R11597	Tubing Ferrule - Pilot N/S
N/S	R11598	R11598	Tubing Nut - Pilot
N/S	R1978	R1978	Tubing Nut & Ferrule - Valve
N/S	B100100	B100100	Fitting - 3/8 Flare to 3/8 Pipe
N/S	R7591	R7591	Flex Line
N/S	R11128	R11128	Power Adaptor, 7.0 VDC
N/S	R11123	R11123	Control Module Harness
N/S	R11237	R11237	Receiver Harness
N/S	R11973	R11973	Receiver Harness Extension
N/S	R11236	R11236	Remote
N/S	R11332	R11332	Flame Sensor Wire
N/S	R11333	R11333	Ignitor Wire
N/S	R3492	R3492	Receptacle (2 Required)
N/S	R3491	R3491	Junction Box Cover

\*A Also requires R11597 and R11598.

\*B Also requires R1978.

# MASTER PARTS DISTRIBUTOR LIST

To Order Parts Under Warranty, please contact your local Empire dealer. See the dealer locator at [www.empirecomfort.com](http://www.empirecomfort.com). To provide warranty service, your dealer will need your name and address, purchase date and serial number, and the nature of the problem with the unit.

To Order Parts After the Warranty Period, please contact your dealer or one of the Master Parts Distributors listed below. This list changes from time to time. For the current list, please click on the Master Parts button at [www.empirecomfort.com](http://www.empirecomfort.com). Please note: Master Parts Distributors are independent businesses that stock the most commonly ordered Original Equipment repair parts for Heaters, Grills, and Fireplaces manufactured by Empire Comfort Systems Inc.

**Dey Distributing**

1401 Willow Lake Boulevard  
Vadnais Heights, MN 55101

**Phone:** 651-490-9191

**Toll Free:** 800-397-1339

**Website:** [www.deydistributing.com](http://www.deydistributing.com)

**Parts: Heater, Hearth and Grills**

**F. W. Webb Company**

200 Locust Street  
Hartford, CT 06114

**Phone:** 860-722-2433

**Toll Free:** 800-243-9360

**Fax:** 860-293-0479

**Toll Free Fax:** 800-274-2004

**Website:** [www.fwwebb.com](http://www.fwwebb.com)

**Parts: Heater, Hearth and Grills**

**East Coast Energy Products**

10 East Route 36  
West Long Branch, NJ 07764

**Phone:** 732-870-8809

**Toll Free:** 800-755-8809

**Fax:** 732-870-8811

**Website:** [www.eastcoastenergy.com](http://www.eastcoastenergy.com)

**Parts: Heater, Hearth and Grills**

## HOW TO ORDER REPAIR PARTS

**Parts Not Under Warranty**

Parts can be ordered through your Service Person, Dealer, or a Master Parts Distributor. See this page for the Master Parts Distributors list. For best results, the **service person or dealer** should order parts through the distributor. Parts can be shipped directly to the **service person/dealer**.

**Warranty Parts**

Warranty parts will need a proof of purchase and can be ordered by your Service Person or Dealer. Proof of purchase is **required** for warranty parts.

All parts listed in the Parts List have a Part Number. When ordering parts, first obtain the Model Number and Serial Number from the name plate on your equipment. Then determine the Part Number (**not** the Index Number) and the Description of each part from the following illustration and part list. Be sure to give all this information . . .

Fireplace Model Number \_\_\_\_\_ Part Description \_\_\_\_\_

Fireplace Serial Number \_\_\_\_\_ Part Number \_\_\_\_\_

Type of Gas (Propane or Natural) \_\_\_\_\_

Do not order bolts, screws, washers or nuts. They are standard hardware items and can be purchased at any local hardware store.

Shipments contingent upon strikes, fires and all causes beyond our control.

# WARRANTY

Empire Comfort Systems Inc. warrants this hearth product to be free from defects at the time of purchase and for the periods specified below. Hearth products must be installed by a qualified technician and must be maintained and operated safely, in accordance with the instructions in the owner's manual. This warranty applies to the original purchaser only and is not transferable. All warranty repairs must be accomplished by a qualified gas appliance technician.

***Limited Lifetime Parts Warranty with a Five-Year Limited Labor Warranty – Combustion Chamber and Heat Exchanger***

If the combustion chamber or heat exchanger (see parts list) fails because of defective workmanship or material, Empire will repair or replace at Empire's option. Within five years from the date of purchase, Empire will pay reasonable labor to have the defective part repaired or replaced at Empire's option.

***Limited Five-Year Parts & Labor Warranty – All Other Components  
(Except Remote Controls, Thermostats, Accessories and Replacement Parts)***

Should any part fail because of defective workmanship or material within five years from the date of purchase, Empire will repair or replace at Empire's option. Within five years from the date of purchase, Empire will pay reasonable labor to have that defect repaired at Empire's option.

***Limited One-Year Parts Warranty – Remote Controls, Thermostats, Accessories, and Parts***

Should any remote control, thermostat, accessory, or other part fail because of defective workmanship within one year from the date of purchase, Empire will repair or replace at Empire's option.

***Duties Of The Owner***

The appliance must be installed by a qualified installer and operated in accordance with the instructions furnished with the appliance. A bill of sale, cancelled check, or payment record should be kept to verify purchase date and establish warranty period. Ready access to the appliance for service.

***What Is Not Covered***

Damages that might result from the use, misuse, or improper installation of this appliance.  
Travel, diagnostic costs and freight charges on warranted parts to and from the factory.  
Claims that do not involve defective workmanship or materials.  
Unauthorized service or parts replacements.  
Removal and reinstallation cost.  
Inoperable due to improper or lack of maintenance.

***How To Get Service***

To make a claim under this warranty, please have your receipt available and contact your installing dealer. Provide the dealer with the model number, serial number, type of gas, and purchase verification. The installing dealer is responsible for providing service and will contact the factory to initiate any warranted parts replacements. Empire will make replacement parts available at the factory. Shipping expenses are not covered.

If, after contacting your Empire dealer, service received has not been satisfactory, contact: Consumer Relations Department, Empire Comfort Systems Inc., PO Box 529, Belleville, Illinois 62222, or send an e-mail to [info@empirecomfort.com](mailto:info@empirecomfort.com) with "Consumer Relations" in the subject line.

***Your Rights Under State Law***

This warranty gives your specific legal rights, and you may also have other rights, which vary from state to state.



SINCE 1932

[www.empirecomfort.com](http://www.empirecomfort.com)

**Empire Comfort Systems Inc.**  
**Belleville, IL**

If you have a general question  
about our products, please e-mail  
us at [info@empirecomfort.com](mailto:info@empirecomfort.com).

If you have a service or repair  
question, please contact your dealer.